

A Multi Boost and Full Bridge Converters For Power Management For Hybrid Vehicle By Battery And Super Capacitors

T.Vijay Muni

(Department of Electrical Sciences, KL University, India)

Abstract : This paper deals with Battery Association Methodology for hybrid vehicle system using planetary gear system is control by DC motor drive with generator set, the energy provides by two super capacitor each super capacitor module is made of 108 cells with a maximum voltage of 270V to define the best topology for the embarked power management. A good power management strategy by using the multi boost and the multi full bridge converter topologies. The simulation results of the two converter topologies are implemented hybrid vehicle system is modulated with DC motor drive with generator set. It is connected to the main vehicle hybrid system to rotate rotor wheel without any speed assumption and jerking. It is easier to modulate at different speeds in hybrid vehicle system ,this system is more accurate than existing vehicle system and it is also applicable for renewable energy sources vehicle system, therefore the cost of the hybrid vehicle is least and most advantageous. The multi boost and multi full bridge converter topologies are studied this module is further extended with planetary gear sub system using battery association.

Keyword: Boost converter, full, bridge, converter, power, management, multi, level, boost,

I. Introduction

In the last few years the pollution problems and the increase of the cost of fossil energy (oil, gas) have become planetary problems. The car manufacturers started to react to the urban pollution problems in nineties by commercializing the electric vehicle. But the battery weight and cost problems were not solved. The batteries must provide energy and peaks power during the transient states. These conditions are severe for the batteries. To decrease these severe conditions, the super capacitors and batteries associate with a good power management present a promising solution. Super capacitors are storage devices which enable to supply the peaks of power to hybrid vehicle during the transient states. During the steady states, batteries will provide the energy requested. This methodology enables to decrease the weight and increases the lifespan of the batteries. Hybridization using batteries and super capacitors [1] for transport applications is needed when energy and power management are requested during the transient sates and steady states. The multi boost and multi full bridge converters will be investigated because of the high power. For range problems, traction batteries used until now cannot satisfy the energy needed for future vehicles. To ensure a good power management in hybrid vehicle, the multi boost and multi full bridge converters topologies and their control are developed. Two topologies proposed for the power management in ECCE Hybrid Vehicle are presented in Fig.1

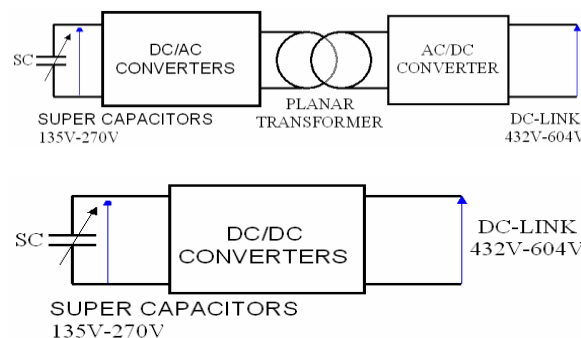

Fig1: Converter topologies for ECCE Hybrid Vehicle

II. DC/DC Converters Topologies and Modeling

2.1. Multi boost and Multi full bridge converters modeling

Figure 2a shows the multi boost converter topology. The general model for this topology [2] is given by equation (1); where (α_1) and (n) define respectively the duty cycle and parallel input converter number.

$$L_n \cdot \frac{d}{dt} (I_{scn}) = V_{scn} - \alpha_1 \cdot V_{bus}$$

$$I_L \cdot V_{bus1} = P_{bus1} + P_{bus2} + \dots + P_{busn} \quad (1)$$

$$\lambda \cdot \frac{d}{dt} (I_{bat}) = V_{bat} - V_{bus1}$$

$$I_{ch} = I_{bat} + k \cdot I_L$$

The voltage drops in the L_n and λ inductances are given by equation (2).

$$V_{L_n} = L_n \cdot \frac{d}{dt} (I_{scn}) \quad (2)$$

$$V_{\lambda} = \lambda \cdot \frac{d}{dt} (I_{bat})$$

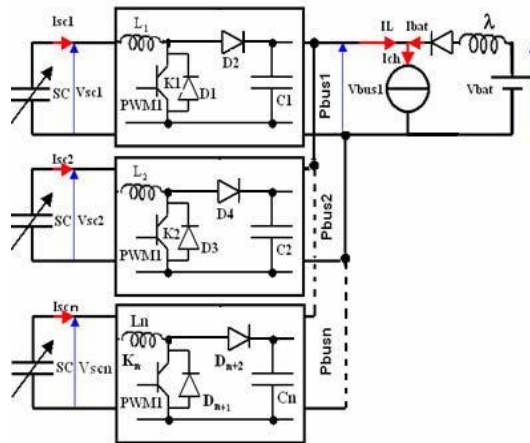

Fig 2(a): Multi boost Converter topology

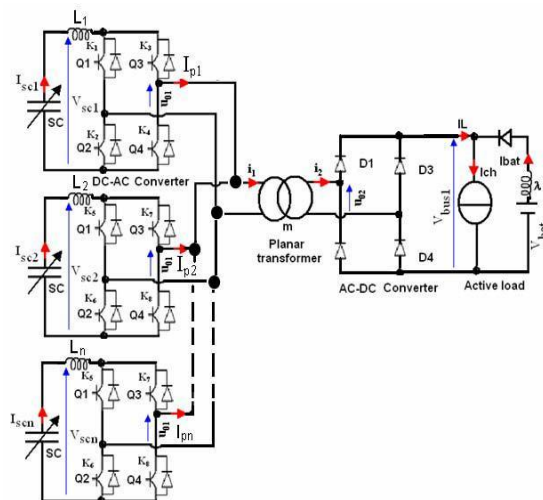

Fig 2(b): Multi full bridge converter topology

The converter average model has a nonlinear behavior because of crosses between α_1 control variable and V_{bus1} parameter. The V_{bus1} V_{sc1} V_{sc2} V_{scn} , I_{ch} and V variables can to disturb the control, they must be measured and used in the estimate of the control law to ensure a dynamics of control [3]. The multi boost converter [4] topology control law which results from the boost converter modeling is presented by α_1 duty cycle (3); where $N_p = \max(n)$ is the maximum number of parallel converters.

$$\alpha_1 = 1 - \frac{1}{N_p} \cdot \frac{(V_{sc1} + V_{sc2} + \dots + V_{scn}) - (V_{L1} + V_{L2} + \dots + V_{Ln})}{V_{bat} - V_\lambda}$$

The multi boost converter control strategy is presented in Fig.3 (a). It ensures the super capacitor modules discharge with variable current. The super capacitors reference current (I) is obtained starting from the power management between batteries and hybrid vehicle DC-link. This control strategy includes the super capacitors and batteries current control loops. PWM1 signal ensures the multi boost converters control during super capacitor modules discharge. To simplify the super capacitors current references estimation, the multi boost converter efficiency (η) was fixed at 85%.

This standardized voltage is compared with two triangular carrier waves of amplitude $V = 1V$ with a switching frequency of 20 kHz. The inverter control strategy is presented in Fig. 3(b); where Q, Q3 and Q4 are the control signals applied to K1, K2, K3 and K switches. The simulations and experimental parameters are presented in table below.

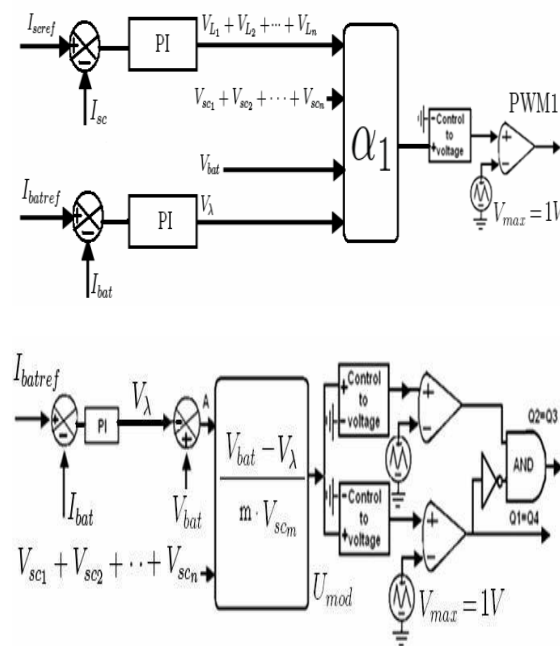

Fig 3. Multi boost and Multi full bridge converters control strategy

2.2 Full bridge converter simulation results

The maximum and minimum voltages of the super capacitor modules are respectively fixed at 270V and 135V. The hybrid vehicle requested current (I_{ch}) is respectively fixed at 100A from 0 to 0.5s, 400A from 0.5s to 18s and 100A from 18s to 20s. Battery reference current (I_{batref}) is fixed at 100A independently of the hybrid vehicle power request. Super capacitor modules voltages (V_{sc1} , V_{sc2}) presented in Fig(a) are identical. The currents amplitudes (I_{sc1} , I_{sc2}) presented in Fig are also identical. Control enables to maintain the battery current (I_{bat}) at 100A; but around 0.5s and 18s the battery current control loop has not enough time to react. The important power of the transient states is ensured by the super capacitors modules (IL).

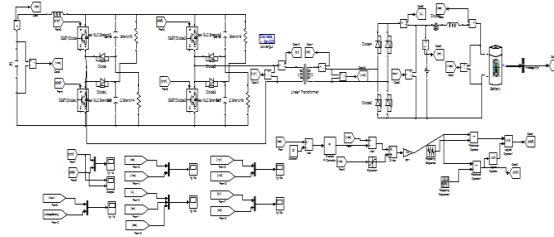

Fig 4: Simulation for full bridge

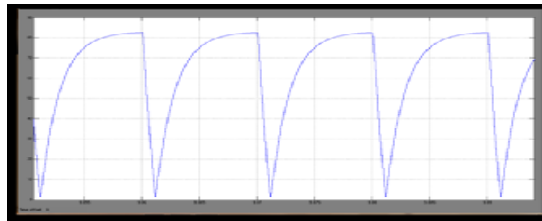

Fig 5: Full Bridge Output Voltage

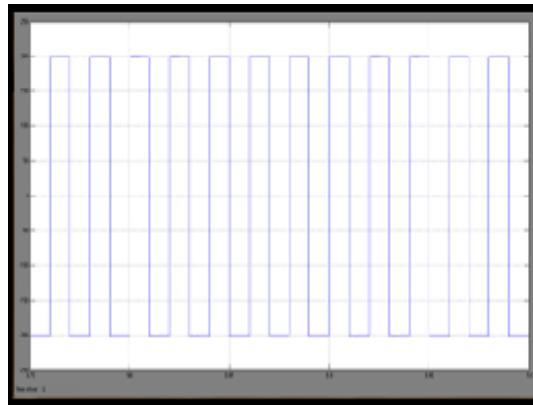

Fig 6: full bridge converter output voltage

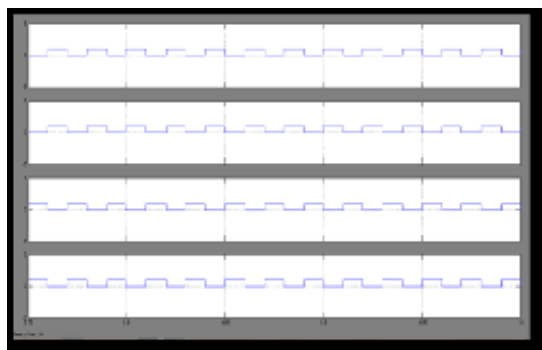

Fig 7: Full bridge converter pulse generator

3.1 Boost converters simulation results

The boost converters experimental test is carried out in the following conditions: During the super capacitors discharge, the batteries current reference (I_{batref}) is fixed at 13A so that, the super capacitors modules provide hybrid vehicle power request during the transient states. For these tests, the hybrid vehicle request (I_{ch}) was fixed at 53A. The experimental and simulations results of the modules voltage are compared. The (I_{sc1}) and (I_{sc2}) experimental currents are not identical Figs because the super capacitors dispersion and the power electronic circuits (boost converters) inequality. The first boost converter ensures 50% and the second ensures also 50% of the DC-link current (I_L). In other words the two super capacitors modules ensure a (I_L) current of 40A to hybrid vehicle as presented in and 13A only is provided by the batteries.

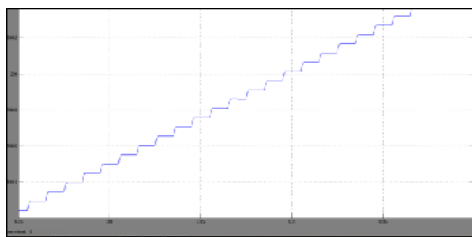

Fig 8: boost converter with Dc-machine load

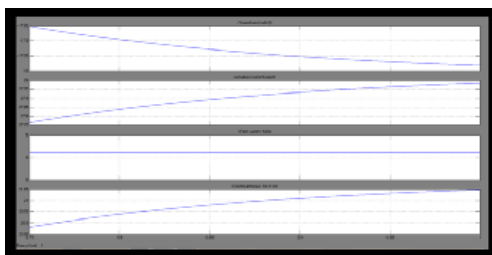

Fig 9: simulation of speed & armature current

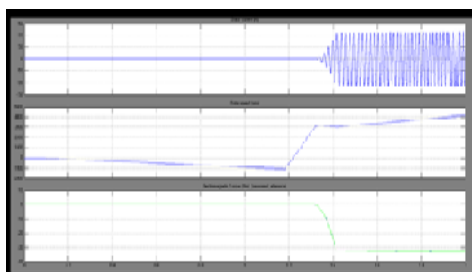

Fig 10: Simulation of generator state current, rotor speed, Electromagnetic torque

III. Conclusion

This paper concentrates on Battery Association Methodology for hybrid vehicle using planetary gear system which is control by DC motor drive with generator set. The multi boost and full bridge converter topologies are implemented with super capacitors to reduce cost and good power management in hybrid vehicle system, full bridge simulation test condensations were different from that of boost converter topology, so at the time it is not easy to make a good power comparison between the two topologies. However, multi full bridge converter topology is well suitable to adapt the level of available voltage to the DC-link, for low voltage and high current applications such as super capacitors. The full bridge converter is higher efficiency, therefore the multi boost and full bridge converter is used in traction system and it ensures good power management.

This system is further extended in planetary gear system which is applicable for vehicling system it is most accurate main energy system and it is also applicable for Renewable Energy Sources vehicling system Therefore the system is least cost and more advantageous the motor and generator is combining to change the battery and as well as the vehicle system is improving any voltage system, speed fluctuations and jerking.

References

- [1] J.M Zimmerman's, P. Zadora, J. Cheng, Y. Van Merlo, and Ph. Lataire. Modeling and design of super capacitors as peak power uniform hybrid electric vehicles. Vehicle Power and Propulsion, IEEE Conference, 7-9 September, page 8pp, 2005.
- [2] Huang Jean Chiu, Hsian Ming Li-Wei Lin, and Ming-Hsiang Tseng. A multiple- input dc/dc converter for renewable energy systems. ICIT2005, IEEE, 14-17 December, pages 1304–1308, 2005.
- [3] M.B. Camera, H. Gallous, F. Gusting, and A. Breton. Control strategy of hybrid sources for transport applications using super capacitors and batteries. IPEMC2006, 13-16 August, Shanghai, P.R.CHINA, 1:1–5, 2006.
- [4] L. Solero, A. Lidozzi, and J.A. Pomilo. Design of multiple-input power converter for hybrid vehicles. IEEE transactions on power electronics, 20, Issue 5, 2005.
- [5] Xin KONG and A. KHA. Analysis and implementation of a high efficiency, interleaved current-fed full bridge converter for fuel cell system. IEEE, 28-01 Nov, 1:474–479, 2005.
- [6] M.B. Camera, F. Gustin, H. Gualous and A. Berthon. Studies and realization of the buck-boost and full bridge converters with multi sources system for the hybrid vehicle applications. Second European Symposium on Super capacitors and Applications, ESSCAP 2006, Lausanne, Switzerland, 2-3 November, 2006.
- [7] Huang-Jen Chiu, Hsiu-Ming, Li-Wei Lin, Ming-Hsiang Tseng. A Multiple-Input DC/DC Converter for Renewable Energy Systems, Industrial Technology, ICIT2005, IEEE international Conference, 14-17 December 2005, Pages: 1304-1308

-
- [8] LOUNIS Zohra. APPOTS DES TECHNIQUES DE CABLAGES LAMINAIRES DANS UN ONDULEUR a IGBT DE MOYENNE PUISSANCE. PhD thesis, Institute National Poly technique de Lorraine, 2000.
- [9] Seong-Jeub Jeon, Gyu-Hyeong Cho. A Zero-Voltage and Zero-Current Switching Full Bridge DC-DC Converter with Transformer Isolation, IEEE Transactions on power Electronics, Vol.16, No.5, September 2001, Pages: 573-580