

An High Step-up Interleaved DC-DC Boost Converter fed with PV

K. Eswar Rao

PG Scholar, Department of EEE
GIET (A)
Rajahmundry, Andhra Pradesh, India

B.V.R.S. Bhanu Seshu

Assistant Professor, Department of EEE
GIET (A)
Rajahmundry, Andhra Pradesh, India

Abstract— *The high-voltage step-up dc-dc converters are required as an interface between the available low voltage sources and the output loads, which are operated at much higher voltages. Examples of such applications are as follows. Different distributed energy storage components such as batteries, fuel cells, and ultra capacitors are used in the power trains of hybrid electric vehicles (HEV), electric vehicles (EV), and fuel cell vehicles (FCV). Telecom and the computer industry utilize the standard batteries, with low voltage levels, as back-up power source. The automotive headlamps, using the high-intensity discharge lamp ballasts.*

Keywords— *DC-DC converter, dual coupled inductors, high gain, input-parallel output-series.*

I. INTRODUCTION

An Interleaved boost converter usually combines more than two conventional topologies, and the current in the element of the interleaved boost converter is half of the conventional topology in the same power condition. Besides, the input current ripple and output voltage ripple of the interleaved boost converter are lower than those of the conventional topologies. The single boost converter can use the zero-voltage switching (ZVS) and/or zero-current switching (ZCS) to reduce the switching loss of the high-frequency switching [1]–[4], [13]–[16], [18]. However, they are considered for the single topology. Many soft-switching techniques are then introduced to the interleaved boost converters. The interleaved boost converters with ZCS or ZVS are proposed in [5]–[8], [17]. These topologies have higher efficiency than the conventional boost converter because the proposed circuits have decreased the switching losses of the main switches with ZCS or ZVS. Nevertheless, these circuits can just achieve the junction of ZVS or ZCS singly or need more auxiliary circuits to reach the soft switching. In [9], the soft-switching circuit for the interleaved boost converter is proposed. However, its main switches are zero-current turn-ON and zero-voltage turn-OFF and the converter works in the discontinuous mode. The maximum duty cycle of the converter is also limited. In [10], it does not reduce the switching losses of the interleaved boost converter by the soft switching techniques, but it decreases the voltage stresses of

the switches by the double-voltage technique with the help of the double-voltage capacitor. This topology has a characteristic that the operational analysis is not equivalent in $D > 50\%$ and $D < 50\%$. A soft-switching bridgeless power factor correction circuit is shown in [11]. It is not the aforementioned interleaved boost converter, but it is two conventional boost converters working in the ac input source. Its two main circuits use the common resonant circuit, so it has less resonant elements. This topology has lighter weight and costs less. And this circuit reduces the switching losses and improves the efficiency by ZVS technique, but it does not improve the turn-OFF switching losses by a ZCS technique. This paper proposes a novel interleaved boost converter with both characteristics of zero-voltage turn-ON and zero-current turn-OFF for the main switches to improve the efficiency with a wide range of load. The voltage stresses of the main switches and auxiliary switch are equal to the output voltage and the duty cycle of the proposed topology can be increased to more than 50%. The proposed converter is the parallel of two boost converters and their driving signals stagger 180° and this makes the operation assumed symmetrical. Moreover, by establishing the common soft-switching module, the soft-switching interleaved converter can further reduce the size and cost.

II. LITERATURE SURVEY

2.1 DC-DC converters

DC-DC converters are an important component as power electronics interfaces for photovoltaic generators and other renewable energy sources. Most renewable power sources, such as photovoltaic power systems and fuel cells, have quite low-voltage output and require series connection or a voltage booster to provide enough voltage output. Boost converters are popularly employed in equipments for different applications, as pre regulators or even integrated with the latter-stage circuits or rectifiers into single-stage circuits. Interleaved method used to improve power converter performance in terms of efficiency, size, conducted electromagnetic emission, and transient response.

The benefits of interleaving include high power capability, modularity, and improved reliability. However, an interleaved topology improves converter performance at the cost of additional inductors, power switching devices, and output rectifiers. The power loss in a magnetic component decreases when the size of the inductor increases though both the low power loss and small volume are required. This means that there is a trade-off relationship between the power loss and the magnetic component size. Therefore, the design of magnetic components in converters is one of the important challenging problems. There are several well-known strategies for selecting a core for the design of magnetic components, for example, the area product (A_p) method and the core geometry (K_g) method. The A_p method is widely used for designing the inductors and transformers for dc-dc power converters operating in CCM and DCM. On the other hand, the concept of the K_g approach is to select a proper core satisfying the electromagnetic conditions, the restriction of the core window area, and the restriction of the winding loss, simultaneously. This method is useful to design inductors and transformers with low core and ac winding losses.

2.2 Types of DC-DC converters

- Buck Converter
- Boost Converter
- Buck-Boost Converter
- Cuk Converter
- Charge-pump Converter

2.3 Boost Converter

A boost converter (step-up converter) is a DC-to-DC power converter with an output voltage greater than its input voltage. It is a class of switched-mode power supply (SMPS) containing at least two semiconductor switches (a diode and a transistor) and at least one energy storage element, a capacitor, inductor, or the two in combination. Filters made of capacitors (sometimes in combination with inductors) are normally added to the output of the converter to reduce output voltage ripple.

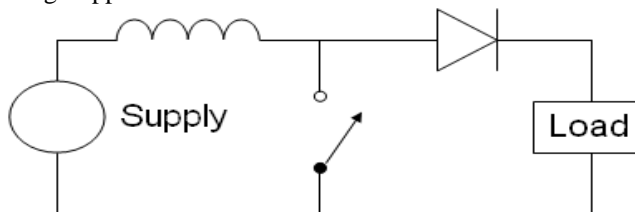

Fig: 2.1 The basic schematic of a boost converter

Power for the boost converter can come from any suitable DC sources, such as batteries, solar panels, rectifiers and DC generators. A process that changes one DC voltage to a different DC voltage is called DC to DC conversion. A boost converter is a DC to DC converter with an output voltage greater than the source voltage. A boost converter is sometimes called a step-up converter since it “steps up” the source voltage. Since power ($P = VI$) must be conserved, the output current is lower than the source current.

2.4 Circuit analysis

1) 2.4.1 Operating principle

The key principle that drives the boost converter is the tendency of an inductor to resist changes in current. In a boost converter, the output voltage is always higher than the input voltage. A schematic of a boost power stage is shown in Figure 2.2. When the switch is closed, current flows through the inductor, which stores energy from the current in a magnetic field. During this time, the switch acts like a short circuit in parallel with the diode and the load, so no current flows to the right hand side of the circuit.

When the switch is opened, the short circuit is removed and the load is back in play in the circuit. This represents a sudden increase in the impedance of the circuit, which, by Ohm's law will demand either a decrease in current, or an increase in voltage. The inductor will tend to resist such a sudden change in the current, which it does by acting as a voltage source in series with the input source, thus increasing the total voltage seen by the right hand side of the circuit and thereby preserving (for a brief moment) the current level that was seen when the switch was closed. This is done using the energy stored by the inductor. Over time, the energy stored in the inductor will discharge into the right hand side of the circuit, bringing the net voltage back down.

If the switch is cycled fast enough, the inductor will not discharge fully in between charging stages, and the load will always see a voltage greater than that of the input source alone when the switch is opened. Also while the switch is opened, the capacitor in parallel with the load is charged to this combined voltage. When the switch is then closed and the right hand side is shorted out from the left hand side, the capacitor is therefore able to provide the voltage and energy to the load. During this time, the blocking diode prevents the capacitor from discharging through the switch. The switch must of course be opened again fast enough to prevent the capacitor from discharging too much.

The basic principle of a Boost converter consists of 2 distinct states:

- in the On-state, the switch S (see figure 2.2) is closed, resulting in an increase in the inductor current.
- in the Off-state, the switch is open and the only path offered to inductor current is through the fly back diode D, the capacitor C and the load R. This result in transferring the energy accumulated during the On-state into the capacitor.
- The input current is the same as the inductor current is not discontinuous as in the buck converter and the requirements on the input filter are relaxed compared to a buck converter

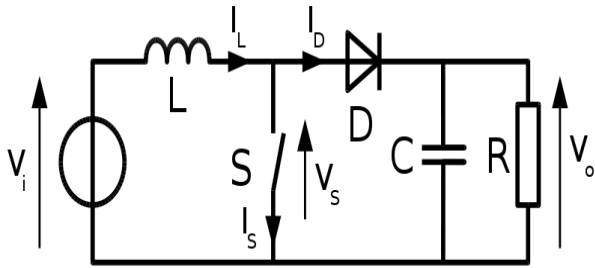

Fig 2.2 schematic diagram of Boost converter

2.4.2 Continuous mode

When a boost converter operates in continuous mode, the current through the inductor (I_L) never falls to zero. The output voltage can be calculated as follows, in the case of an ideal converter (i.e. using components with an ideal behavior) operating in steady conditions.

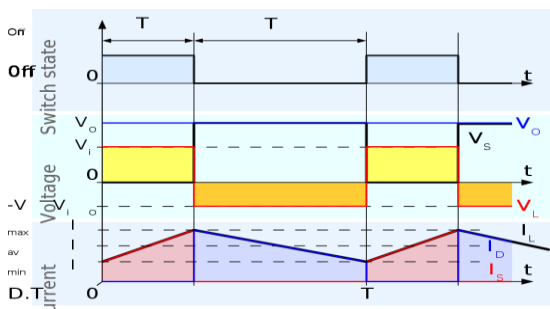

Fig. 2.3 : Waveforms of current and voltage in a boost converter operating in continuous mode

2.4.3 Discontinuous mode

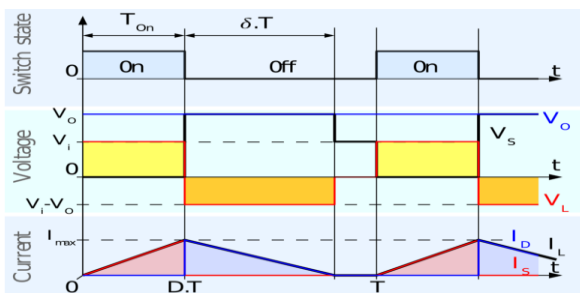

Fig. 2.4: Waveforms of current and voltage in a boost converter operating in discontinuous mode.

III. INTERLEAVED BOOST OPERATION

3.1 Introduction

An Interleaved boost converter usually combines more than two conventional topologies, and the current in the element of the interleaved boost converter is half of the conventional topology in the same power condition. Besides, the input current ripple and output voltage ripple of the interleaved boost converter are lower than those of the conventional topologies. The single boost converter can use the zero-voltage switching (ZVS) and/or zero-current switching (ZCS) to reduce the switching loss of the high-

frequency switching [1]–[4], [13]–[16], [18]. However, they are considered for the single topology. Many soft-switching techniques are then introduced to the interleaved boost converters. The interleaved boost converters with ZCS or ZVS are proposed in [5]–[8], [17]. These topologies have higher efficiency than the conventional boost converter because the proposed circuits have decreased the switching losses of the main switches with ZCS or ZVS. Nevertheless, these circuits can just achieve the junction of ZVS or ZCS singly or need more auxiliary circuits to reach the soft switching. In [9], the soft-switching circuit for the interleaved boost converter is proposed. However, its main switches are zero-current turn-ON and zero-voltage turn-OFF and the converter works in the discontinuous mode. The maximum duty cycle of the converter is also limited. In [10], it does not reduce the switching losses of the interleaved boost converter by the soft switching techniques, but it decreases the voltage stresses of the switches by the doublevoltage technique with the help of the double-voltage capacitor. This topology has a characteristic that the operational analysis is not equivalent in $D > 50\%$ and $D < 50\%$. A soft-switching bridgeless power factor correction circuit is shown in [11]. It is not the aforementioned interleaved boost converter, but it is two conventional boost converters working in the ac input source. Its two main circuits use the common resonant circuit, so it has less resonant elements. This topology has lighter weight and costs less. And this circuit reduces the switching losses and improves the efficiency by ZVS technique, but it does not improve the turn-OFF switching losses by a ZCS technique. This paper proposes a novel interleaved boost converter with both characteristics of zero-voltage turn-ON and zero-current turn-OFF for the main switches to improve the efficiency with a wide range of load. The voltage stresses of the main switches and auxiliary switch are equal to the output voltage and the duty cycle of the proposed topology can be increased to more than 50%. The proposed converter is the parallel of two boost converters and their driving signals stagger 180° and this makes the operation assumed symmetrical. Moreover, by establishing the common soft-switching module, the soft-switching interleaved converter can further reduce the size and cost.

3.2 Analysis of Operation

Fig. 3.1 shows the proposed circuit. It uses the interleaved boost topology and applies the common soft-switching circuit. The resonant circuit consists of the resonant inductor L_r , resonant capacitor C_r , parasitic capacitors C_{Sa} and C_{Sb} , and auxiliary Switch S_r to become a resonant way to reach ZVS and ZCS functions. Fig. 3.2 shows the two operating modes of this circuit, depending on whether the duty cycle of the main switch is more than 50% or not.

3.2.1 Operational Analysis of $D < 50\%$ Mode

The operating principle of the proposed topology is described in this section. There are 24 operational modes in the complete cycle. Only the 12 modes related to the main switch S_a are analyzed, because the interleaved topology is symmetrical. Fig. 3.3 shows the related waveforms when the duty cycle of the main

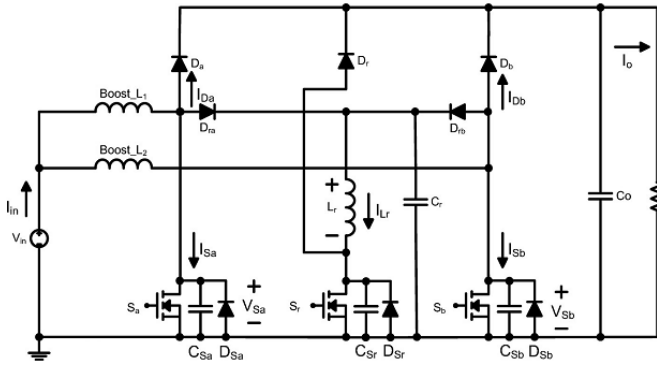

Fig. 3.1 A novel interleaved boost converter with characteristics of zero-voltage switching and zero-current switching

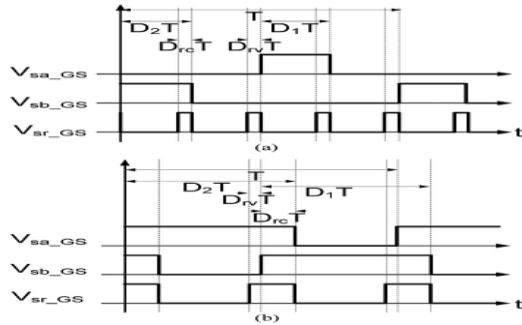

Fig. 3.2 Switching waveforms of the main switches Sa and Sb and auxiliary Switch Sr. (a) $D < 50\%$ mode. (b) $D > 50\%$ mode.

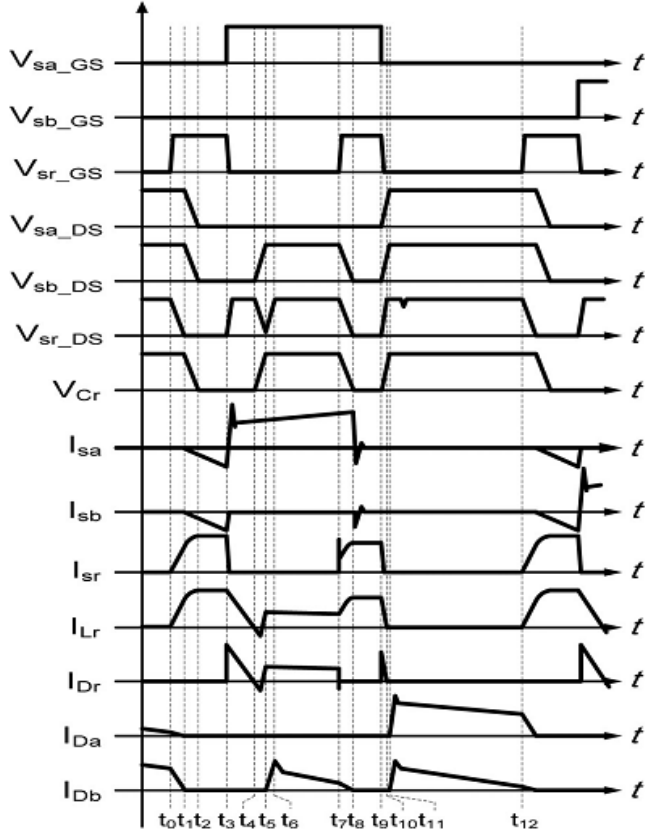

Fig. 3.3 Related waveforms ($D < 50\%$)

switch is less than 50%. There are some assumptions to simplify the circuit analysis.

- 1) All power switches and diodes are ideal.
- 2) The input inductor and output capacitor are ideal.
- 3) The two inductors are equal; $\text{Boost_L}_1 = \text{Boost_L}_2$.

- 4) The duty cycles of the main switches are equal; $D_1 = D_2$.

Mode 1 [$t_0 - t_1$]: Fig. 4(a) shows the equivalent circuit. In this mode, the main switches S_a and S_b are turned OFF, the auxiliary switch S_r and the rectifier diodes D_a and D_b are turned ON, and the clamped diode D_r is turned OFF. The voltages across the parasitic capacitors C_{Sa} and C_{Sb} of the main switches and the resonant capacitor C_r are all equal to the output voltage; i.e., $V_{Sa} = V_{Sb} = V_{Sr} = V_o$ in the previous mode. The resonant inductor current I_{Lr} linearly ramps up until it reaches I_{in} at $t = t_1$. When the resonant inductor current I_{Lr} is equal to I_{in} , the mode 1 will end. Then, the rectifier diodes are turned OFF.

The interval time t_{01} is

$$t_{01} = L_r \cdot \frac{I_{in}}{V_o}$$

IV. SIMULATION RESULTS

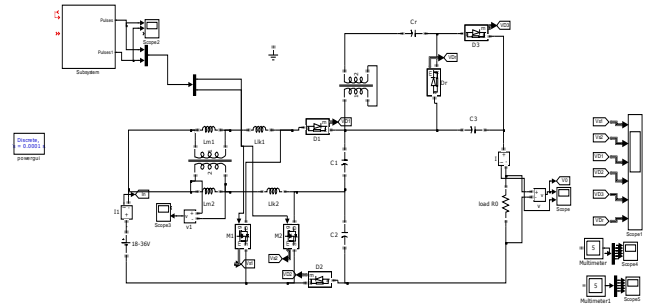

Fig.4.1 Conventional Simulation Circuit

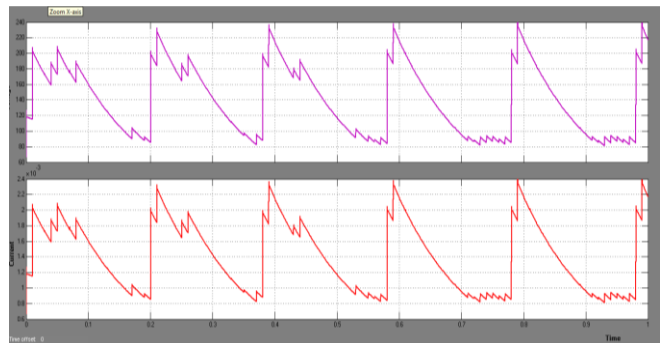

Fig:4.2 Conventional Circuit Voltage and Current

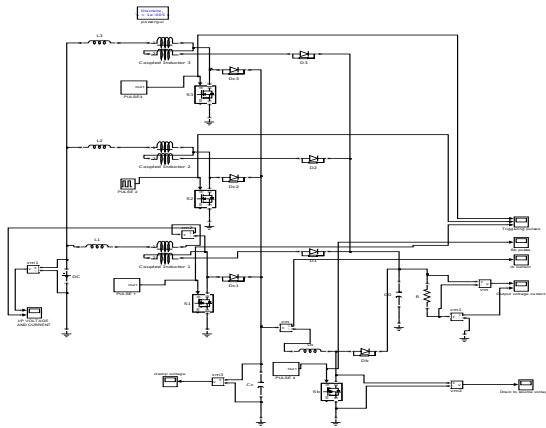

Fig:4.3 Proposed Simulation Circuit

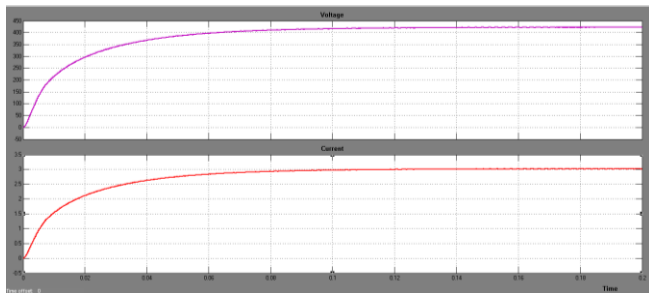

Fig: 4.4 Voltage and Current for Proposed Simulation Circuit

From the above voltage and current waveforms of both conventional and proposed circuits we clearly observed that the proposed circuit will convert into pure DC voltage and current .

V. CONCLUSION

A novel interleaved boost converter with both zero-voltage switching and zero-current-switching functions is proposed in this paper. The duty cycle of this topology can be more or less than 50%. A prototype circuit of this converter has been implemented. Its input voltage is from 150 to 250 V and output voltage is 400 V. The load variation is from 200 to 600 W. It has many characteristics.

- 1) The main switches Sa and Sb can achieve both ZVS and ZCS.
- 2) The voltage stress of all switches is equal to the output voltage.
- 3) It has the smaller current stress of elements.
- 4) It uses the resonant inductor Lr, resonant capacitor Cr, parasitic capacitors CSa and CSb, and auxiliary switch Sr to become a common resonant way to reach ZVS and ZCS of the main switches Sa and Sb.
- 5) The driving circuit can automatically detect whether the driving signals of the main switches are more than 50% or not and get the driving signal of the auxiliary switch.
- 6) The users can only apply the ZVS or ZCS function just by the adjustment of the driving circuit.
- 7) The efficiency is 94.6% with output power of 600 W and input voltage of 150 V and it is 95.5% with output power of 400 W and input voltage of 250 V.

References

- [1] G. C. Hua, W. A. Tabisz, C. S. Leu, N. Dai, R. Watson, and F. C. Lee, "Development of a DC distributed power system," in Proc. IEEE 9th Annu. Appl. Power Electron. Conf. Expo., Feb. 1994, vol. 2, pp. 763–769.
- [2] C. M. Wang, "A new single-phase ZCS-PWM boost rectifier with high power factor and low conduction losses," IEEE Trans. Ind. Electron., vol. 53, no. 2, pp. 500–510, Apr. 2006.
- [3] H. M. Suryawanshi, M. R. Ramteke, K. L. Thakre, and V. B. Borghate, "Unity-power-factor operation of three-phase AC–DC soft switched converter based on boost active clamp topology in modular approach," IEEE Trans. Power Electron., vol. 23, no. 1, pp. 229–236, Jan. 2008.
- [4] C. J. Tseng and C. L. Chen, "A passive lossless snubber cell for nonisolated PWM DC/DC converters," IEEE Trans. Ind. Electron., vol. 45, no. 4, pp. 593–601, Aug. 1998.
- [5] Y.-C. Hsieh, T.-C. Hsueh, and H.-C. Yen, "An interleaved boost converter with zero-voltage transition," IEEE Trans. Power Electron., vol. 24, no. 4, pp. 973–978, Apr. 2009.
- [6] C. M. de Oliveira Stein, J. R. Pinheiro, and H. L. Hey, "A ZCT auxiliary commutation circuit for interleaved boost converters operating in critical conduction mode," IEEE Trans. Power Electron., vol. 17, no. 6, pp. 954–962, Nov. 2002.
- [7] C. A. Canesin and F. A. S. Goncalves, "A 2kW Interleaved ZCS-FM boost rectifier digitally controlled by FPGA device," in Proc. IEEE Power Electron. Spec. Conf., Jul. 2006, vol. 2, pp. 1382–1387.
- [8] W. Li and X. He, "ZVT interleaved boost converters for high-efficiency, high step-up DC–DC conversion," IET Electron. Power Appl., vol. 1, no. 2, pp. 284–290, Mar. 2007.
- [9] G. Yao, A. Chen, and X. He, "Soft switching circuit for interleaved boost converters," IEEE Trans. Power Electron., vol. 22, no. 1, pp. 80–86, Jan. 2007.
- [10] J. Yungtaek and M. M. Jovanovic, "Interleaved PFC boost converter with intrinsic voltage-doubler characteristic," in Proc. IEEE Power Electron. Spec. Conf., Jun. 2006, pp. 1888–1894.
- [11] H.-Y. Tsai, T.-H. Hsia, and D. Chen, "A novel soft-switching bridgeless power factor correction circuit," in Proc. Eur. Conf. Power Electron. Appl., Sep. 2007, pp. 1–10.
- [12] S. S. Saha, B. Majumdar, T. Halder, and S. K. Biswas, "New fully softswitched boost-converter with reduced conduction losses," in Proc. IEEE Int. Conf. Power Electron. Drives Syst., 2005, vol. 1, pp. 107–112.
- [13] G. Hua, C.-S. Leu, Y. Jiang, and F. C. Y. Lee, "Novel zero-voltage-transition PWM converters," IEEE Trans. Power Electron., vol. 9, no. 2, pp. 213–219, Mar. 1994.
- [14] E. Adib and H. Farzanehfard, "Family of soft-switching PWM converters with current sharing in switches," IEEE Trans. Power Electron., vol. 24, no. 4, pp. 979–985, Apr. 2009.
- [15] E. Adib and H. Farzanehfard, "Zero-voltage-transition PWM converters with synchronous rectifier," IEEE Trans. Power Electron., vol. 25, no. 1, pp. 105–110, Jan. 2010.
- [16] S.-H. Park, S.-R. Park, J.-S. Yu, Y.-C. Jung, and C.-Y. Won, "Analysis and design of a soft-switching boost converter with an HI-bridge auxiliary resonant circuit," IEEE Trans. Power Electron., vol. 25, no. 8, pp. 2142–2149, Aug. 2010.
- [17] S. Park and S. Choi, "Soft-switched CCM boost converters with high-voltage gain for high-power applications," IEEE Trans. Power Electron., vol. 25, no. 5, pp. 1211–1217, May 2010.
- [18] I. Aksoy, H. Bodur, and A. Faruk Bakan, "A new ZVT-ZCT-PWM DC–DC converter," IEEE Trans. Power Electron., vol. 25, no. 8, pp. 2093–2105, Aug. 2010.
- [19] M. Kazimierczuk and D. Czarkowski, Resonant Power Converter. Hoboken, NJ: Wiley, 2011.
- [20] I. Batarseh, Power Electronic Circuits. Hoboken, NJ: Wiley, 2004.
- [21] N. Mohan, T. M. Undeland, and W. P. Robbins, Power Electronic Converters, Applications, and Design. Hoboken, NJ: Wiley, 2007.
- [22] D. W. Hart, Introduction to Power Electronics. Englewood Cliffs, NJ: Prentice-Hall, 1997.