

## Solar PV Array Fed BLDC Motor Using Zeta Converter For Water Pumping Applications

A. Arun Vikram\*<sup>1</sup>, R. Navaneeth \*<sup>2</sup>, M. Naresh Kumar \*<sup>3</sup>, R. Vinoth \*<sup>4</sup>

\*<sup>1</sup>. Department of EEE, K. Ramakrishnan College of Technology, Tiruchirapalli, Tamil Nadu, India  
arunavikram@gmail.com

\*<sup>2</sup>. Department of EEE, K. Ramakrishnan College of Technology, Tiruchirapalli, Tamil Nadu, India  
navaneethr111097@gmail.com

\*<sup>3</sup>. Department of EEE, K. Ramakrishnan College of Technology, Tiruchirapalli, Tamil Nadu, India  
naresh.muruges97@gmail.com

\*<sup>4</sup>. Department of EEE, K. Ramakrishnan College of Technology, Tiruchirapalli, Tamil Nadu, India  
vinothvino0002002@gmail.com

**Abstract :** This paper proposes a simple, cost effective and efficient brushless DC (BLDC) motor drive for solar photovoltaic (SPV) array fed water pumping system. A zeta converter is utilized in order to extract the maximum available power from the SPV array. The proposed control algorithm eliminates phase current sensors and adapts a fundamental frequency switching of the voltage source inverter (VSI), thus avoiding the power losses due to high frequency switching. No additional control or circuitry is used for speed control of the BLDC motor. The speed is controlled through a variable DC link voltage of VSI. An appropriate control of zeta converter through the incremental conductance maximum power point tracking (INC-MPPT) algorithm offers soft starting of the BLDC motor. The proposed water pumping system is designed and modeled such that the performance is not affected under dynamic conditions. The suitability of proposed system at practical operating conditions is demonstrated through simulation results using MATLAB/ Simulink followed by an experimental validation.

**Keywords -** BLDC motor, SPV array, Water pump, Zeta converter, VSI, INC-MPPT.

### I. INTRODUCTION

The drastic reduction in the cost of power electronic devices and annihilation of fossil fuels in near future invite to use the solar photovoltaic (SPV) generated electrical energy for various applications as far as possible. The water pumping, a standalone application of the SPV array generated electricity is receiving wide attention now a days for irrigation in the fields, household applications and industrial use. Although several researches have been carried out in an area of SPV array fed water pumping, combining various DC-DC converters and motor drives, the zeta converter in association with a permanent magnet brushless DC (BLDC) motor is not explored precisely so far to develop such kind of system. However, the zeta converter has been used in some other SPV based applications [1-3]. Moreover, a topology of SPV array fed BLDC motor driven water pump with zeta converter has been reported and its significance has been presented more or less in [4]. Nonetheless, an experimental validation is missing and the absence of extensive literature review and comparison with the existing topologies, have concealed the technical contribution and originality of the reported work.

The merits of both BLDC motor and zeta converter can contribute to develop a SPV array fed water pumping system possessing a potential of operating satisfactorily under dynamically changing atmospheric conditions. The BLDC motor has high reliability, high efficiency, high torque/inertia ratio, improved cooling, low radio frequency interference and noise[12] and requires practically no maintenance [5-6]. On the other hand, a zeta converter exhibits following advantages over the conventional buck, boost, buck-boost converters and Cuk converter when employed in SPV based applications.

- Belonging to a family of buck-boost converters, the zeta converter may be operated either to increase or to decrease the output voltage. This property offers a boundless region for maximum power point tracking (MPPT) of a SPV array [7]. The MPPT can be performed with simple buck [8] and boost [9] converter if MPP occurs within prescribed limits.
- This property also facilitates the soft starting of BLDC motor unlike a boost converter which habitually steps up the voltage level at its output, not ensuring soft starting.

- Unlike a classical buck-boost converter [10], the zeta converter has a continuous output current. The output inductor makes the current continuous and ripple free.
- Although consisting of same number of components as a Cuk converter [11], the zeta converter operates as non-inverting buck-boost converter unlike an inverting buck-boost and Cuk converter. This property obviates a requirement of associated circuits for negative voltage sensing hence reduces the complexity and probability of slow down the system response [12].

These merits of the zeta converter are favorable for proposed SPV array fed water pumping system. An incremental conductance (INC) MPPT algorithm [8, 13-18] is used to operate the zeta converter such that SPV array always operates at its MPP.

The existing literature exploring SPV array based BLDC motor driven water pump [19-22] is based on a configuration shown in Fig. 1. A DC-DC converter is used for MPPT of a SPV array as usual. Two phase currents are sensed along with Hall signals feedback for control of BLDC motor, resulting in an increased cost. The additional control scheme causes increased cost and complexity, which is required to control the speed of BLDC motor. Moreover, usually a voltage source inverter (VSI) is operated with high frequency PWM pulses, resulting in an increased switching loss and hence the reduced efficiency. However, a Z-source inverter (ZSI) replaces DC-DC converter in [22], other schematic of Fig. 1 remaining unchanged, promising high efficiency and low cost. Contrary to it, ZSI also necessitates phase current and DC link voltage sensing resulting in the complex control and increased cost.

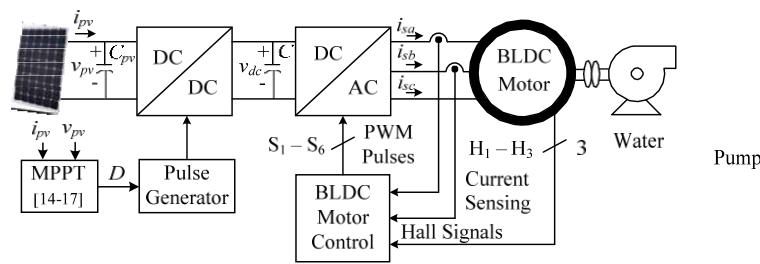

Fig. 1 Conventional SPV fed BLDC motor driven water pumping system

To overcome these problems and drawbacks, a simple, cost-effective and efficient water pumping system based on SPV array fed BLDC motor is proposed, by modifying the existing topology (Fig. 1) to as shown in Fig. 2. A zeta converter is utilized in order to extract the maximum power available from a SPV array, soft starting and speed control of BLDC motor coupled to a water pump. Due to a single switch, this converter has very good efficiency and offers boundless region for MPPT. This converter is operated in continuous conduction mode (CCM) resulting in a reduced stress on its power devices and components. Furthermore, the switching loss of VSI is reduced by adopting fundamental frequency switching resulting in an additional power saving and hence an enhanced efficiency. The phase currents as well as the DC link voltage sensors are completely eliminated, offering simple and economical system without scarifying its performance. The speed of BLDC motor is controlled, without any additional control, through a variable DC link voltage of VSI. Moreover, a soft starting of BLDC motor is achieved by proper initialization of MPPT algorithm of SPV array. These features offer an increased simplicity of proposed system.

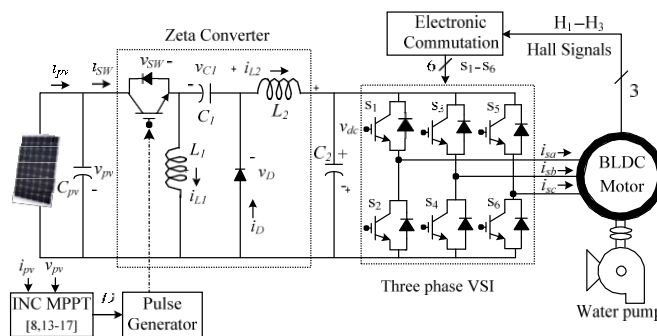

Fig. 2 Proposed SPV-Zeta converter fed BLDC motor drive for water pump.

The advantages and desirable features of both zeta converter and BLDC motor drive contribute to develop a simple, efficient, cost-effective and reliable water pumping system based on solar PV energy. Simulation results using MATLAB/Simulink and experimental performances are examined to demonstrate the starting, dynamics and steady state behavior of proposed water pumping system subjected to practical operating conditions. The SPV array and BLDC motor are designed such that proposed system always exhibits good performance regardless of solar irradiance level.

## II. CONFIGURATION OF PROPOSED SYSTEM

The structure of proposed SPV array fed BLDC motor driven water pumping system employing a zeta converter is shown in Fig. 2. The proposed system consists of (left to right) a SPV array, a zeta converter, a VSI, a BLDC motor and a water pump. The BLDC motor has an inbuilt encoder. The pulse generator is used to operate the zeta converter. A step by step operation of proposed system is elaborated in the following section in detail.

## III. OPERATION OF PROPOSED SYSTEM

The SPV array generates the electrical power demanded by the motor-pump. This electrical power is fed to the motor- pump via a zeta converter and a VSI. The SPV array appears as a power source for the zeta converter as shown in Fig. 2. Ideally, the same amount of power is transferred at the output of zeta converter which appears as an input source for the VSI. In practice, due to the various losses associated with a DC-DC converter [23], slightly less amount of power is transferred to feed the VSI. The pulse generator generates, through INC- MPPT algorithm, switching pulses for IGBT (Insulated Gate Bipolar Transistor) switch of the zeta converter. The INC- MPPT algorithm uses voltage and current as feedback from SPV array and generates an optimum value of duty cycle. Further, it generates actual switching pulse by comparing the duty cycle with a high frequency carrier wave. In this way, the maximum power extraction and hence the efficiency optimization of the SPV array is accomplished.

The VSI, converting DC output from a zeta converter into AC, feeds the BLDC motor to drive a water pump coupled to its shaft. The VSI is operated in fundamental frequency switching through an electronic commutation of BLDC motor assisted by its built-in encoder. The high frequency switching losses are thereby eliminated, contributing in an increased efficiency of proposed water pumping system.

## IV. DESIGN OF PROPOSED SYSTEM

Various operating stages shown in Fig. 2, are properly designed in order to develop an effective water pumping system, capable of operating under uncertain conditions. A BLDC motor of 2.89 kW power rating and a SPV array of 3.4 kW peak power capacity under standard test conditions (STC) are selected to design the proposed system. The detailed design of various stages such as SPV array, zeta converter and water pump are described as follows.

### A. Design of SPV Array

As per above discussion, the practical converters are associated with various power losses. In addition, the performance of BLDC motor-pump is influenced by associated mechanical and electrical losses. To compensate these losses, the size of SPV array is selected with slightly more peak power capacity to ensure the satisfactory operation regardless of power losses. Therefore, the SPV array of peak power capacity of  $P_{mpp} = 3.4$  kW under STC (STC: 1000W/m<sup>2</sup>, 25°C, AM 1.5), slightly more than demanded by the motor-pump is selected and its parameters are designed accordingly. SolarWorld make Sunmodule® Plus SW 280 mono [24] SPV module is selected to design the SPV array of an appropriate size. Electrical specifications of this module are listed in Table I and numbers of modules required to connect in series/parallel are estimated by selecting the voltage of SPV array at MPP under STC as,  $V_{mpp} = 187.2$  V.

The current of SPV array at MPP,  $I_{mpp}$  is estimated as,

$$I_{mpp} = P_{mpp}/V_{mpp} = 3400/187.2 = 18.16 \text{ A} \quad (1)$$

The numbers of modules required to connect in parallel are as,

$$N_p = I_{mpp}/I_m = 18.16/9.07 = 2 \quad (2)$$

Connecting 6 modules in series, having 2 strings in parallel, a SPV array of required size is designed for the proposed system and its data are given in Appendix A.

Table I: Specifications Of Sunmodule<sup>®</sup> Plus Sw 280 Mono Spv Module

Peak power, $P_m$ (Watt)	280
Open circuit voltage, $V_o$ (V)	39.5
Voltage at MPP, $V_m$ (V)	31.2
Short circuit current, $I_s$ (A)	9.71
Current at MPP, $I_m$ (A)	9.07
Number of cells connected in series, $N_{ss}$	60

**B. Design of Zeta Converter**

The zeta converter is the next stage to the SPV array. Its design consists of an estimation of various components such as input inductor,  $L_1$ , output inductor,  $L_2$  and intermediate capacitor,  $C_1$ . These components are designed such that the zeta converter always operates in CCM resulting in reduced stress on its components and devices.

**C. Estimation of DC Link Capacitor of VSI**

A new design approach for estimation of DC link capacitor of the VSI is presented here. This approach is based on a fact that 6<sup>th</sup> harmonic component of the supply (AC) voltage is reflected on the DC side as a dominant harmonic in the three phase supply system [25]. Here, the fundamental frequencies of output voltage of the VSI are estimated corresponding to the rated speed and the minimum speed of BLDC motor essentially required to pump the water. These two frequencies are further used to estimate the values of their corresponding capacitors. Out of these two estimated capacitors, larger one is selected to assure a satisfactory operation of proposed system even under the minimum solar irradiance level.

**V. CONTROL OF PROPOSED SYSTEM**

The proposed system is controlled in two stages. These two control techniques, viz. MPPT and electronic commutation are discussed as follows.

**A. INC-MPPT Algorithm**

An efficient and commonly used INC-MPPT technique [8, 13] in various SPV array based applications is utilized in order to optimize the power available from a SPV array and to facilitate a soft starting of BLDC motor. This technique allows perturbation in either the SPV array voltage or the duty cycle. The former calls for a PI (Proportional-Integral) controller to generate a duty cycle [8] for the zeta converter, which increases the complexity. Hence, the direct duty cycle control is adapted in this work. The INC-MPPT algorithm determines the direction of perturbation based on the slope of  $P_{pv}$ - $v_{pv}$  curve, shown in Fig. 3. As shown in Fig. 3, the slope is zero at MPP, positive on the left and negative on the right of MPP.

$$\left. \begin{aligned} dP_{pv} / dV_{pv} &= 0; \text{ at MPP} \\ dP_{pv} / dV_{pv} &< 0; \text{ left of MPP} \\ dP_{pv} / dV_{pv} &> 0; \text{ right of MPP} \end{aligned} \right\} (3)$$

Therefore, (14) is rewritten as

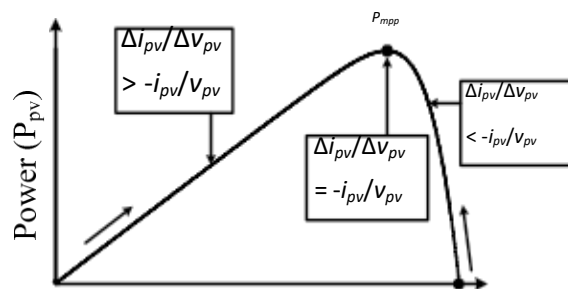

Fig. 3 Illustration of INC-MPPT with SPV array  $P_{pv}$ - $v_{pv}$  characteristics

Thus, based on the relation between incremental conductance and instantaneous conductance, the controller decides the direction of perturbation as shown in Fig.3, and increases/decreases the duty cycle accordingly. For instance, on the right of MPP, the duty cycle is increased with a fixed perturbation size until the direction reverses. Ideally, the perturbation stops once the operating point reaches the MPP. However, in practice, operating point oscillates around the MPP.

As the perturbation size reduces, the controller takes more time to track the MPP of SPV array. An intellectual agreement between the tracking time and the perturbation size is held to fulfill the objectives of MPPT and soft starting of BLDC motor. In order to achieve soft starting, the initial value of duty cycle is set as zero. In addition, an optimum value of perturbation size ( $\Delta D = 0.001$ ) is selected, which contributes to soft starting and also minimizes oscillations around the MPP.

**A. Electronic Commutation of BLDC Motor**

The BLDC motor is controlled using a VSI operated through an electronic commutation of BLDC motor. An electronic commutation of BLDC motor stands for commutating the currents flowing through its windings in a predefined sequence using a decoder logic. It symmetrically places the DC input current at the centre of each phase voltage for 120°. Six switching pulses are generated as per the various possible combinations of three Hall-effect signals. These three Hall-effect signals are produced by an inbuilt encoder according to the rotor position.

A particular combination of Hall-effect signals is produced for each specific range of rotor position at an interval of 60° [5-6]. The generation of six switching states with the estimation of rotor position is tabularized in Table II. It is perceptible that only two switches conduct at a time, resulting in 120° conduction mode of operation of VSI and hence the reduced conduction losses. Besides this, the electronic commutation provides fundamental frequency switching of the VSI, hence losses associated with high frequency PWM switching are eliminated. TETRA 115TR9.2, a motor power company make BLDC motor [28] with inbuilt encoder is selected for proposed system and its detailed specifications are given in Appendix C.

Table II: Switching States For Electronic Commutation Of Bldc Motor

Rotor position $\theta(^{\circ})$	Hall Signals			Switching States					
	$H_3$	$H_2$	$H_1$	$S_1$	$S_2$	$S_3$	$S_4$	$S_5$	$S_6$
NA	0	0	0	0	0	0	0	0	0
0-60	1	0	1	1	0	0	1	0	0
60-120	0	0	1	1	0	0	0	0	1
120-180	0	1	1	0	0	1	0	0	1
180-240	0	1	0	0	1	1	0	0	0
240-300	1	1	0	0	1	0	0	1	0
300-360	1	0	0	0	0	0	1	1	0
NA	1	1	1	0	0	0	0	0	0

**VI. SIMULATED PERFORMANCE OF PROPOSEDSYSTEM**

Performance evaluation of proposed SPV array fed BLDC motor driven water pump employing a zeta converter is carried out using simulated results. The proposed system is designed, modelled and simulated considering the random and instant variations in solar irradiance level and its suitability is demonstrated by testing the starting, steady state and dynamic behaviour as illustrated in Figs. 4-5. To demonstrate the suitability of the system under dynamic condition, solar irradiance level is instantly reduced from 600 W/m<sup>2</sup> to 200 W/m<sup>2</sup> and then increased to 1000 W/m<sup>2</sup> as shown in Fig. 5 (a).

**A. Performance of SPV Array**

Fig.4(a) exhibits the starting and steady state performances of SPV array at 1000 W/m<sup>2</sup>. The MPP is properly tracked. The tracking time is intentionally increased at the starting by adapting a low value of perturbation size ( $\Delta D = 0.001$ ) in order to achieve the soft starting of BLDC motor. The low value of  $\Delta D$  causes the reduced rate of rise of DC link voltage of VSI resulting in a smooth and soft starting of the motor. However, a negligible tracking time is required under the dynamic variation in irradiance level as shown in Fig. 5(a).

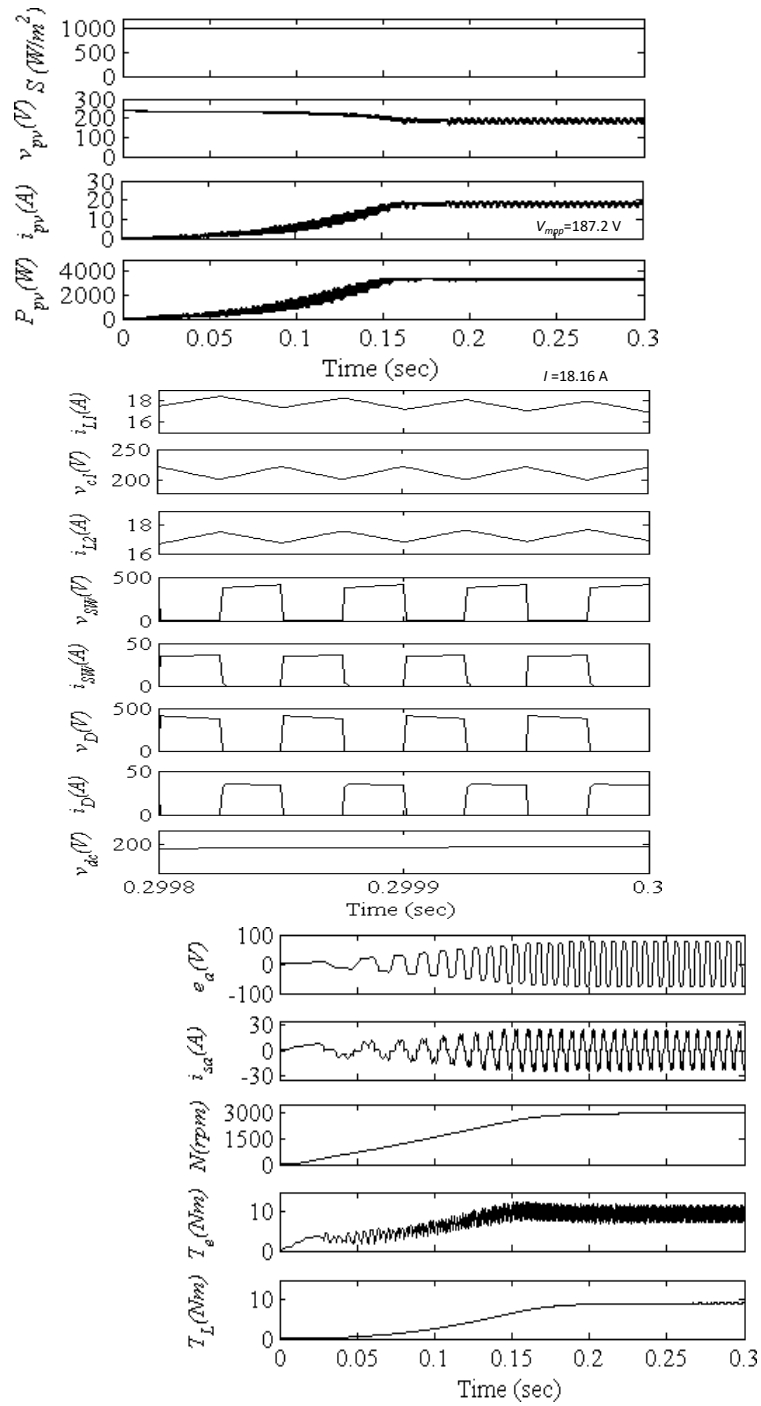

Fig. 4 Starting and steady state performances of the proposed SPV array based Zeta converter fed BLDC motor drive for water pump (a) SPV array variables, (b) Zeta converter variables, and (c) BLDC motor-pump variables.

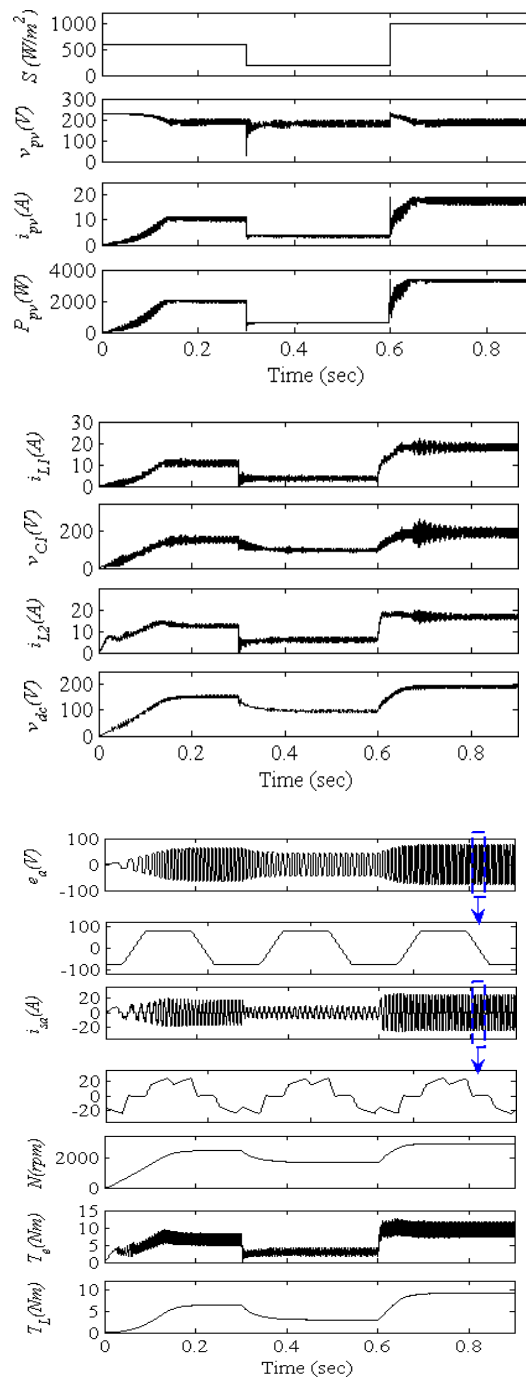

Fig. 5 Dynamic performances of the proposed SPV array based Zeta converter fed BLDC motor drive for water pump (a) SPV array variables, (b) Zeta converter variables, and (c) BLDC motor-pump variables.

**B. Performance of Zeta Converter**

Fig. 4(b) presents the steady state performance of zeta converter at 1000 W/m<sup>2</sup>. The input inductor current  $i_{L1}$ , intermediate capacitor voltage,  $v_{c1}$ , output inductor current,  $i_{L2}$ , voltage stress on IGBT switch,  $v_{sw}$ , current stress on IGBT switch,  $i_{sw}$ , blocking voltage of the diode,  $v_D$ , current through diode,  $i_D$ , and DC link voltage,  $v_{dc}$  are presented. The zeta converter is operated in CCM. The operation of converter in this mode reduces the stress on power devices and components. These converter indices follow the variation in the weather condition and vary in proportion to the solar irradiance level, such as  $i_{L1}$ ,  $v_{c1}$ ,  $i_{L2}$  and  $v_{dc}$  shown in Fig. 5(b). The zeta converter automatically changes its mode of operation from buck mode to boost mode and vice versa according to the irradiance level in order to optimize the output power of SPV array. A small amount of ripples in the zeta converter variables are observed caused by permitting the ripples up to an extent in



**C. Performance of BLDC Motor-Pump**

The starting and steady state behaviors of the BLDC motor-pump at  $1000 \text{ W/m}^2$  is shown in Fig. 4(c). All the motor indices such as the back EMF,  $e_a$ , the stator current,  $i_{sa}$ , the speed,  $N$ , the electro-magnetic torque developed,  $T_e$  and the load torque,  $T_L$  reach their corresponding rated values under steady state condition. The soft starting along with the stable operation of motor-pump is observed and hence the successful operation of proposed system is verified. However, a small pulsation in  $T_e$  results in due to the electronic commutation of the BLDC motor. As the solar irradiance level alters, all the BLDC motor – pump indices vary in proportion to the solar irradiance level as shown in Fig. 5(c). The BLDC motor always attains a higher speed than 1100 rpm, a minimum speed required to pump the water at a minimum solar irradiance level of  $200 \text{ W/m}^2$ . Performance of BLDC motor- pump is not deteriorated by weather conditions and it pumps the water successfully.

**VII. HARDWARE VALIDATION OF PROPOSED SYSTEM**

The various performances of SPV array, zeta converter and BLDC motor-pump are validated on a developed prototype of the proposed system, which is presented in Fig. 6. The system constitutes a SPV array simulator (AMETEK ETS 600×17DPVF), zeta converter, VSI (SEMIKRON MD B6CI 600/415-35F), real time DSP controller (dSPACE 1104) to perform MPPT and electronic commutation, BLDC motor (Motor Power Company make) coupled with a DC generator (Benn make) and resistive load bank. A volumetric pump is realized by driving a DC generator feeding a resistive load. Thus, this motor-generator-load set becomes analogous to a volumetric pump, possessing proportional relationship between torque and speed. Because of the rating constraints, experiments are carried out with a 1-HP, 2000 rpm BLDC motor fed by a 900- Wp PV array. A voltage sensor (LV-25P) and a current sensor (LA-55P) are used for MPPT control. To provide the isolation between real time controller and gate drivers, the optocouplers (6N136) are used. Detailed specifications of SPV array, zeta converter and BLDC motor used for test are given in Appendices. Experimental performance of proposed system are analyzed in the following sections.

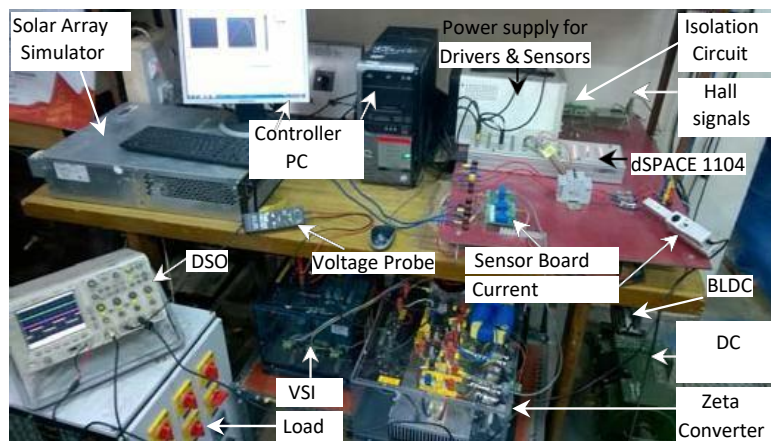

Fig. 6 Photograph of a developed prototype of the proposed system.

**A. Performance of SPV Array**

The performance of developed system is tested for solar irradiance level varying from  $400 \text{ W/m}^2$  to  $1000 \text{ W/m}^2$ . The recorded  $p_{pv}$ - $v_{pv}$  and  $i_{pv}$ - $v_{pv}$  characteristics shown in Figs. 7(a) and (b), respectively at  $1000 \text{ W/m}^2$  and  $400 \text{ W/m}^2$  verify excellent performance of MPPT. A tracking efficiency for both irradiance levels is observed more than 99%.



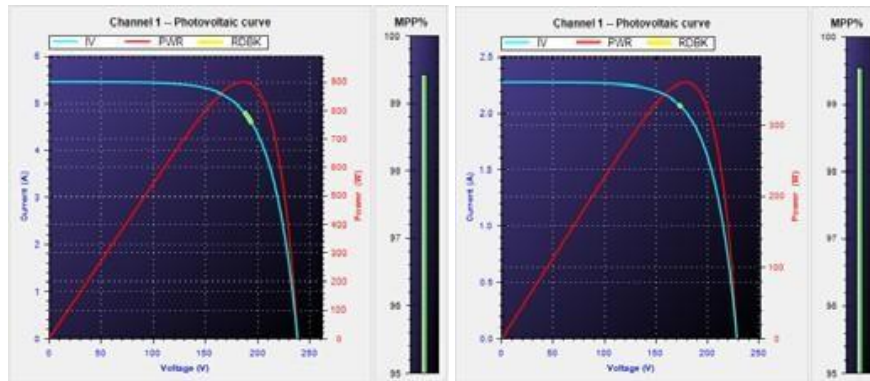
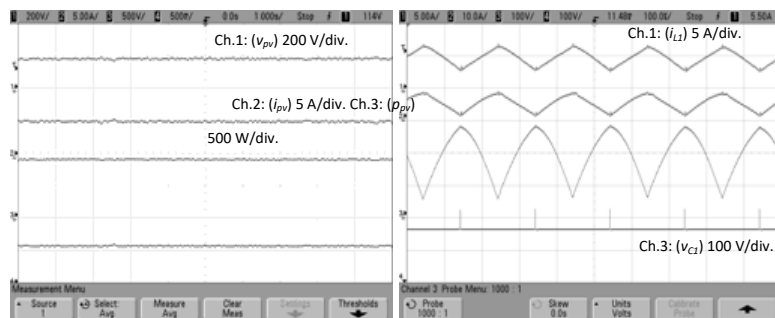

Fig. 7 MPPT performance at (a) 1000 W/m<sup>2</sup>, (b) 400 W/m<sup>2</sup>

**B. Steady State Performance at 1000 W/m<sup>2</sup>**

The steady state performances of SPV array, zeta converter and BLDC motor-pump at 1000 W/m<sup>2</sup> are validated using the recorded waveforms shown in Fig. 8 and elaborated in following sub-sections

- 1) *Performance of SPV Array:* The recorded waveforms of various SPV array indices  $v_{pv}$ ,  $i_{pv}$ ,  $p_{pv}$  along with the duty ratio,  $D$  are shown in Fig. 8(a). These indices correspond to MPP. The operation of zeta converter in boost mode is observed at  $D=0.52$ .
- 2) *Operation of Zeta Converter:* Fig. 8(b) represents a set of the zeta converter indices  $i_{L1}$ ,  $i_{L2}$ ,  $v_{C1}$  and  $v_{d}$ . Furthermore, Fig. 8(c) represents another set of the indices  $v_{sw}$ ,  $i_{sw}$ ,  $v_D$  and  $i_D$ . These indices justify the operation of converter in CCM and limited stress on its power devices. The peak voltage and peak current of the switch are observed as 400 V and 13.7 A respectively. Similarly, the peak voltage and peak current of the diode are observed as 500 V and 14 A respectively. The IGBT and diode operate in a complementary fashion.
- 3) *Performance of BLDC Motor:* Fig. 8(d) exhibits the recorded waveforms of stator currents of all three phases,  $i_{sa}$ ,  $i_{sb}$ ,  $i_{sc}$  and speed,  $N$ . The BLDC motor indices reach their rated values of 2000 rpm and 3.6 A. A 1-HP (746 W) motor draws 900 W from PV array, offering 83% system efficiency.



(a)

(b)

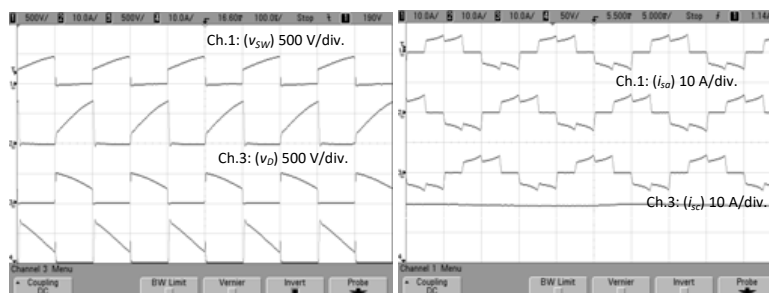

(c)

(d)

Fig. 8 Steady state performance of (a) SPV array, (b) - (c) zeta converter, (d) BLDC motor, at 1000 W/m<sup>2</sup>

**C. Dynamic Performance of Proposed System**

To demonstrate the satisfactory performance of system under dynamically varying atmospheric condition, the solar irradiance is varied from 400 W/m<sup>2</sup> to 1000 W/m<sup>2</sup> as shown in Fig. 9(a) and vice versa, as shown in Fig. 9(b). The recorded waveforms, shown in Fig. 9 are  $i_{pv}$ ,  $v_{dc}$ ,  $i_{sa}$  and  $N$ . It is clearly observed that the MPP is tracked accurately. The zeta converter quickly changes its mode of operation following the variation in atmospheric condition. The change in solar irradiance from 400 W/m<sup>2</sup> to 1000 W/m<sup>2</sup> results in the change in  $i_{pv}$  from 2.0 A to 4.8 A,  $v_{dc}$  from 111 V to 196 V,  $i_{sa}$  from 2.5 A to 3.6 A and  $N$  from 1150 rpm to 2000 rpm. Thus, the water pumping is not interrupted at all.

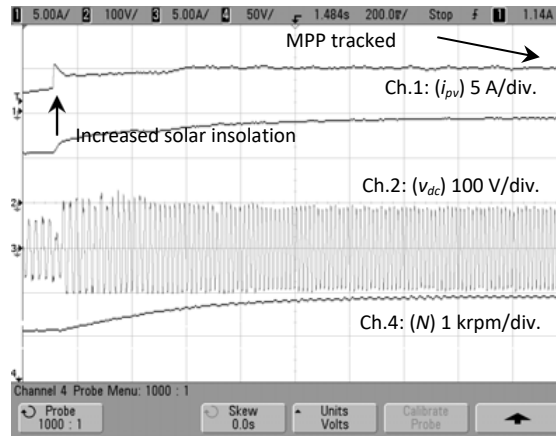

(a)

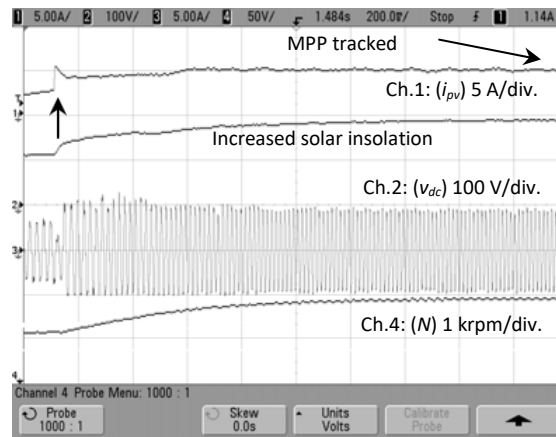

(b)

Fig.9 Dynamic performance under varying solar insolation level (a) 400 W/m<sup>2</sup> to 1000 W/m<sup>2</sup>, (b) 1000 W/m<sup>2</sup> to 400 W/m<sup>2</sup>

**D. Starting Performance of Proposed System**

The soft starting of BLDC motor, as shown in Figs. 10(a) and (b) respectively at both solar irradiances of 1000 W/m<sup>2</sup> and 400 W/m<sup>2</sup>, is validated using recorded waveforms of  $i_{pv}$ ,  $v_{dc}$ ,  $i_{sa}$  and  $N$ . The initial duty ratio is set at 0.1 to start the motor. All these indices reach their steady state values at MPP of SPV array. The motor attains 1150 rpm at 400 W/m as shown in Fig. 10(b), a sufficient speed to pump the water.

**E. Efficiency Estimation of Proposed System**

The experimental measurements are considered to estimate the efficiency of the proposed water pumping system. Table III and Fig. 11 show the estimated efficiency of the SPV array fed BLDC motor-pump, subjected to the random variation in solar insolation level, where  $P_{pv}$ ,  $P_m$  and  $\eta$  are respectively the maximum power available from the SPV array, mechanical power output of the BLDC motor and efficiency of the overall system. Hence this efficiency includes the efficiency of INC-MPPT algorithm, zeta converter, VSI and BLDC motor. A very good efficiency of 83% is obtained at the standard solar insolation level of 1000 W/m<sup>2</sup> whereas it is 71% even at 400 W/m<sup>2</sup>.

### VIII. CONCLUSION

The SPV array-zeta converter fed VSI-BLDC motor-pump has been proposed and its suitability has been demonstrated through simulated results and experimental validation. The proposed system has been designed and modeled appropriately to accomplish the desired objectives and validated to examine various performances under starting, dynamic and steady state conditions. The performance evaluation has justified the combination of zeta converter and BLDC motor for SPV array based water pumping. The system under study has shown various desired functions such as MPP extraction of the SPV array, soft starting of BLDC motor, fundamental frequency switching of VSI resulting in a reduced switching losses, speed control of BLDC motor without any additional control and an elimination of phase current and DC link voltage sensing, resulting in the reduced cost and complexity. The proposed system has operated successfully even under minimum solar irradiance.

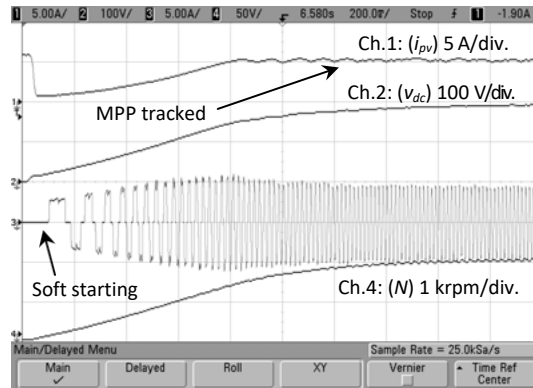

(a)

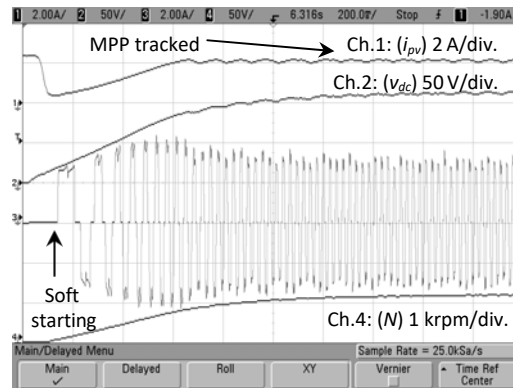

(b)

Fig.10 Starting performance at (a) 1000 W/m<sup>2</sup>, (b) 400 W/m<sup>2</sup>

Table III: Estimated Efficiency Of Proposed System



$S$ (W/m <sup>2</sup> )	$P_{pv}$ (W)	$P_m$ (W)	$\eta$ (%)
400	360	255	71.0
500	450	326	72.4
650	585	438	74.8
800	720	565	78.5
900	810	660	81.5
1000	900	746	83.0

### REFERENCES

[1] Abdin.Z, Webb.C.J and MacAGray.E, "Modelling and Simulation of a Proton Exchange Membrane (PEM) Electrolyser Cell," *International Journal on Hydrogen Energy*, vol. 40, no.5, pp.13243-13257, September 2015. <http://dx.doi.org/10.1016/j.ijhydene.2015.07.129>.

- [2] Ali, A. Nazar. "Ride through Strategy for a Three-Level Dual Z-Source Inverter Using TRIAC." *Scientific Research publication* 7.ISSN Online: 2153-1293 (2016): 3911-3921.
- [3] Ramkumar, R., and N. Tejaswini. "A novel low cost three arm Ac automatic voltage regulator." *Advances in Natural and Applied Sciences* 10, no. 3 (2016): 142-152.
- [4] Seyezhai.R and Mathur.B.L, "Mathematical Modeling of Proton Exchange Membrane Fuel Cell," *International Journal of Computer Applications*, vol.20, no.5, pp.816-825, April 2011.
- [5] Ramkumar,R., et al." A Novel Low Cost Three Arm Ac Automatic Voltage Regulator" *Advances in Natural and Applied Sciences* ISSN: 1995-0772 AENSI Publication EISSN: 1998-1090. 2016 March 10(3): pages 142-151.
- [6] R.Ramkumar "High current and High Voltage Gain Soft Switched Multiphase Multilevel Modular DC-DC Converter." *International Journal of Applied Engineering Research* 10, no. 0973-4562 (2015): 7686-7689.
- [7] Radwan.T.S, and Rahman.M.A, "Performance Analysis of a Cost Effective 4-Switch 3-Phase Inverter Fed IM Drive," *Iranian Journal of Electrical and Computer Engineering*, vol.5, no.2, pp.97-102, June 2006.
- [8] Ganesh, Rajendran Jai, et al. "Fault Identification and Islanding in DC Grid Connected PV System." *Scientific Research Publishing 7.Circuits and Systems*, 7, 2904-2915. (2016): 2904-2915.
- [9] Wen Wang, An Luo and Xianyong, "Space vector pulse-width modulation algorithm and DC-side voltage control strategy of three-phase four-switch active power filters," *Power Electronics, IET* , vol.6, no.1, pp.125-135, January 2013. doi: 10.1049/iet-pel.2012.0391
- [10] Ali, A. Nazar. "Performance Enhancement of Hybrid Wind/Photo Voltaic System Using Z Source Inverter with Cuk-sepic Fused Converter." *Research Journal of Applied Sciences, Engineering and Technology* 7.ISSN: 2040-7459; (2014): 3964-3970.
- [11] Kalavalli,C., et al. "Single Phase Bidirectional PWM Converter for Microgrid System." *International Journal of Engineering and Technology (IJET)* ISSN : 0975-4024 Vol 5 No 3 Jun-Jul 2013.
- [12] K.S.Srikanth, "A Three Phase Multi Level Converter For grid Connected PV System", (as special issue on power electric converter) *International journal of Power Electronics and Drive Systems (IJPEDS)* Vol. 5, No. 1, pp 71-75 July 2014

**BIBLIOGRAPHY OF AUTHORS (11 PT)**

	<p>Mr. A.Arunvikram completed his BE in PSNA College of Engineering and Technology, Dindigul. He Completed his M.E in PSNA College of Engineering and Technology, Dindigul. And he is having 4years experience on teaching field. Currently he is pursuing his PhD degree in Anna University, Chennai. His area of interest is power Converters, Renewable Energy.</p>
	<p>Master Navaneeth. R completed his higher secondary education in Kendriya Vidyalaya No.1 OFT, Trichy. He is now perusing BE in K. Ramakrishnan College Of Technology, Trichy. His area of interest is Electrical Machines.</p>