

Synchronous Reference Frame Control Based Shunt Active Filter for Power Quality improvement

S. Balaji Reddy

PG Scholar, Department of EEE
GIET (A)
Rajahmundry, Andhra Pradesh, India

M.V.Raghavendra Reddy

Assistant Professor, Department of EEE
GIET (A)
Rajahmundry, Andhra Pradesh, India

Abstract— Power Quality means maintaining purely sinusoidal current wave form in phase with a purely sinusoidal voltage wave form throughout in a power system. Due to intensive use of power converters and other non linear loads in industries, an increasing deterioration of the power system voltage and current waveforms has been observed. The most important cause for degrading power quality are harmonic distortion and low power factor. Conventionally, Passive filters have been used as a solution to solve harmonic current problems, but they are not capable of mitigating the low power factor problems. So an improved method of Active Power Filter (APF) used to eliminate the disturbances in current. This paper examines the control of Shunt Active Power Filter (SAPF) with Synchronous Reference Frame (SRF) detection method. Here a twelve pulse diode bridge rectifier will be the non linear load and the switching frequency is set to 10 kHz. Simulation analyses are done using Matlab/Simulink software.

Keywords— Shunt Active Power Filter, Synchronous Reference Frame method.

I. INTRODUCTION (HEADING 1)

Nowadays the growth of power quality problems due to power electronic equipment such as adjustable speed drive, programmable logic controller, electronic lightning, together with other nonlinear loads, is an issue for power engineers. This problem generates harmonics and thereby causes changes in the electrical nature of the current and voltage of the power supply. The problem leads to significant economic losses due to fact that some electrical equipment are sensitive to this power quality problem [1]. The active power filters (APFs) are widely preferred over passive filters as a solution to various power quality (PQ) problems arising from the load or source [2]. This is because passive filters have many drawbacks such as resonance with the system impedance, heavy weight and bulky sizes, sensitivity to the system parameter variation, and possible system overload by ambient harmonic load [3–5].

Active power filter (APF) is a power electronics converter that limits the harmonics and compensates reactive power. APF can compensate nonlinear loads and reactive power in

real time. This is important for stabilizing ac mains and improving power quality [1]. APF is a high voltage power conditioner. Power conditioners are power converters that process power for different applications. Multilevel converters are suitable topologies for APFs. Multilevel converters can output high voltage directly without using transformers or reactors to connect the ac side. Compared with conventional 2-level converter, 3-level H-bridge converters have advantages of having less total harmonic distortion (THD) for output voltage, easy regulation of the dc side voltage due to the separated dc supply structure and convenient design due to the same structure of each converter unit.

The drawbacks of H -bridge converters are that there must be separated dc supplies in each converter unit, increasing number of switches and consequently more voltage drop for converter operation [2]. Multilevel converters can be modulated with pulse width modulation techniques (PWM); excellent harmonic characteristics can be achieved. There are two common modulation strategies for cascaded multilevel converter.

Phase-Shifted PWM (PSPWM) and Level shifted PWM (LSPWM) which is carrier-based sinusoidal PWM techniques. The LSPWM technique offers preferable harmonic characteristic compared to the PSPWM technique. These PWM-based techniques shift harmonics to higher frequencies and generate high frequency harmonics at PWM switching frequency and its multiples. RPWM technique can be used to reduce the amplitudes of these high-frequency harmonics. A new method has been proposed that uses a derivative control and 2-level inverter as a dc-ac converter. The derivative control can amplify noises and two level inverter increases THD. However, the derivative control and 2-level inverter is replaced with PMR controller and 3-level H-bridge respectively in this investigation.

This paper introduces the LSRPWM modulation technique as a combination of RPWM and LSPWM modulation techniques. In order to regulate the power exchange between the grid and APF, and simultaneously provide the high quality sinusoidal current in the ac side, various control strategies such as

predictive compensator, repetitive control, robust control, high performance stationary-frame control, and proportional resonant based compensator have been reported [3]. Controller selection depends on the load nature. So, nonlinear loads (like rectifier load which is used in this project) have output voltage that contains predominantly fifth- and seventh-harmonics other than fundamental. Recently, the idea of using proportional-Multi Resonant (PMR) controllers to preserve high source current quality while feeding nonlinear loads and controlling the sinusoidal currents with zero steady-state error has attracted considerable attention. So, this control structure is sufficient to apply for both balanced- and unbalanced-loading conditions. Therefore, in this method, tracking of sinusoidal signals with zero steady-state error is simply achieved.

In this paper, a PMR based current control with LSRPWM modulation technique is introduced into H-bridge multilevel converter to have a desirable performance from current quality point of view.

II. LITERATURE REVIEW

Power system harmonics are integer multiples of the fundamental power system frequency. The main sources of waveform distortion are electric arc furnaces, fluorescent lamps, electrical machines, transformers etc. The commonly used power electronic devices such as rectifiers, inverters, cycloconverters etc. contribute large amounts of harmonics. Harmonics can cause a variety of unwelcome effects like signal interference, over voltages, data loss, equipment heating, malfunction, very high neutral currents, random tripping of circuit breakers, premature failure of transformers and uninterruptible power supplies and damage. Rotor heating and pulsating output torque caused by harmonics can result in excessive motor heating and inefficiency. High levels of power system harmonics can create voltage distortion and power quality problems [1]. These harmonic distortions in power distribution systems can be suppressed using mainly two approaches. One is Passive Filtering and the other is Active Power Filtering.

A. Passive Filter

The passive filtering is the simplest conventional solution to mitigate the harmonic distortion. Passive filters are inductance, capacitance, and resistance elements configured and tuned to control harmonics. But, they do not always respond correctly to the dynamics of the power systems. They have many disadvantages such as fixed compensation, large size and resonance problems. Passive filters are known to cause resonance, thus affecting the stability of the power distribution systems. Frequency variation of the power distribution system and tolerances in component values affect the passive filtering characteristics. So passive filters might not be able to meet the harmonic limitations of international standards. This may required a retrofit of new filters [2].

B. Active Power Filter

Remarkable progress in power electronics had raised the interest in Active Power Filters for harmonic mitigation. APFs performances are independent of the power distribution system properties. Figure 1 shows the basic block diagram of

active power filter. The working of active power filter consists of mainly three stages. They are: Signal conditioning, Derivation of compensating signal and Generation of gating signal.

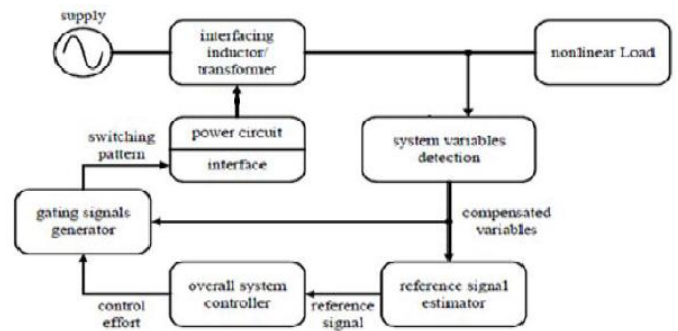

Figure 1: Basic block diagram of APF

Signal conditioning refers to the detection or sensing of harmonics in the power distribution line. As shown in Figure 1, the reference signal estimation is initiated through the detection of essential voltage/current signals sensed by using potential transformers, current transformers etc. The next stage is the derivation of compensating signal from the disrupted wave consists of both fundamental wave and the harmonic content. It can be done by different methods like Fourier transformation method, Instantaneous Reactive Power Theorem, Synchronous Reference Frame Theorem, Synchronous Detection Theorem etc. The third stage is the generation of gating signal for harmonic suppression. So many control techniques like space Vector PWM, repetitive control, hysteresis current control, dead beat control, sliding mode control, fuzzy control etc have been introduced and applied to various configurations of active power filters [3][4].

III. PWM STRATEGIES

Pulse width modulation (PWM) strategies used in a conventional inverter can be modified to use in multilevel converters. The advent of the multilevel converter PWM modulation methodologies can be classified according to switching frequency

3.1 Multilevel carrier-based PWM

Several different two-level multilevel carrier-based PWM techniques have been extended by previous as a means for controlling the active devices in a multilevel converter. The most popular and easiest technique to implement uses several triangle carrier signals and one reference.

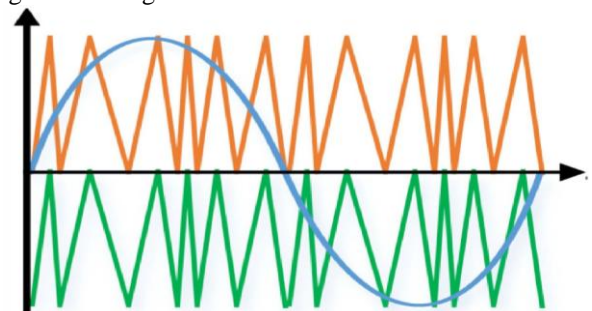

Figure 3.1 LSRPWM carrier wave form

3.2 Types of the PWM techniques

- a) Random pulse width modulation
- b) Level shifted pulse width modulation

3.2.1 Random pulse width modulation

Random PWM schemes achieve spreading of the energy spectrum by randomly switching, random switching frequency and random pulse position. For random PWM schemes research till now has mostly focus on a carrier based implementation.

Acoustic switching noise gets remarkably reduced by increasing the carrier frequency above 18 kHz, however, that increases the switching losses in the inverter and decreases operating efficiency. An inverter with random PWM has an advantage of spread and continuously dispersed output harmonic spectra.

Random Carrier Frequency (RCF-PWM):

The method is based on a random selection of the carrier frequency for each carrier period. The only requirement for RCF-PWM is to maintain the volt-second balance during a carrier period, ensuring that the fundamental frequency component is not affected by the randomization.

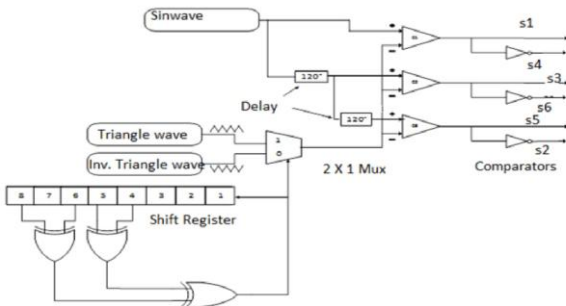

Figure 3.2 Random Carrier Frequencies PWM

The Random Carrier PWM technique uses two different triangular carriers as depicted in Figure. One is of required frequency and the other is 180 degree phase shifted.

The selection of the carrier among these carriers is done by a random bit generated. That is, if '1' is the output carrier 1 (basic) is selected as carrier 2 (180° shifted). The selection is done for ever carrier cycle and the selected carrier is compared with the reference sinusoidal waveform. The Pseudo random carrier modulation scheme is most commonly used for the random triangular frequency generation. Here, the random triangular frequency is achieved in the range of 3 kHz.

Fixed Career frequency- Random PWM (FCF-RPWM):

In this method, the switching period is fixed and pulse position is varied randomly. These methods portray a good closed loop

response.

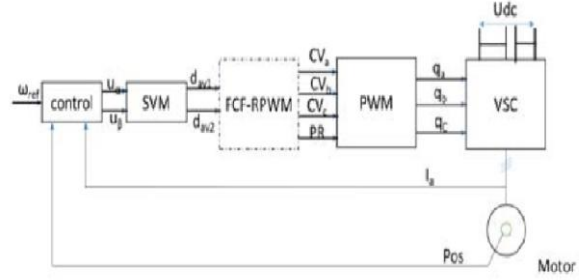

Figure 3.3 FCF-RPWM in open and Closed loop

The control block of FCF- RPWM which can be implemented with open loop or closed loop. Control block calculates the reference voltage vector in α and β plane. SVM block will estimate and compare values for PWM. FF_RPWM block will randomize active vectors and zero vectors in the given modulation period. Duty ratios are converted to compare values for generating random PWM output required by VSC block.

The FCF-RPWM methods, even though easy to synchronize with the control algorithm suffer from problems like current sampling, calculation overhead and spreading effectiveness. The following methods of FCF-RPWM are finding many applications in adjustable speed drives.

3.2.2 Level Shifted Pulse Width Modulation

LSPWM is selected to modulate CHB converters. Relating to the phase variation between individual carriers The level shifted pulse width modulation technique has three types.

- 1 In Phase disposition
- 2. Phase disposition opposition
- 3. Alternate phase opposition disposition

Among these techniques, PD strategy offers the lowest harmonic distortion; thus, this strategy has been employed in this paper. The LSPWM technique bring forward preferable harmonic performance when compared with the PSPWM technique but it eludes the current harmonic cancellation at the high frequency spectrum (which is noise). In order to overcome the effect of high order harmonics, RPWM is a desirable approach. The most common realization of the RPWM strategy is randomization of switching frequency.

IV. PROPORTIONAL MULTI-RESONANT CURRENT CONTROLLER

The proportional + multi-resonant (PMR) [6] controller, which is composed of the traditional proportional resonant (PR) controller and the harmonic resonant controllers of 3th, 5th, and 7th, is used to realize the unbalance control targets. This method can effectively restrain the grid current influence of the grid voltage distortion.

Controller Design:

Once the positive-and negative-sequence of grid voltage and referenced current are determined, the next task is to design the grid controller to ensure that the grid current can follow the referenced signal. Then the PMR controller is adopted in this paper. PMR controller. The PMR transfer function is defined as follows

$$G_{PMR}(s) = k_p + \sum_{m=1,3,5,7} \frac{2k_r m \xi_0 \omega_0 s}{s^2 + 2m \xi_0 \omega_0 s + (m \omega_0)^2}$$

where, k_p is the proportional coefficient and k_r is the multi-resonant coefficient, ω_0 is the fundamental frequency and its value is 100π rad/s, ξ_0 is the resonant factor. As shown in Fig.5, the resonant peaks are existed in the frequency of $m\omega_0$; therefore, the system will have great gains in these frequencies and the zero-error tracking for the referenced current can be realized.

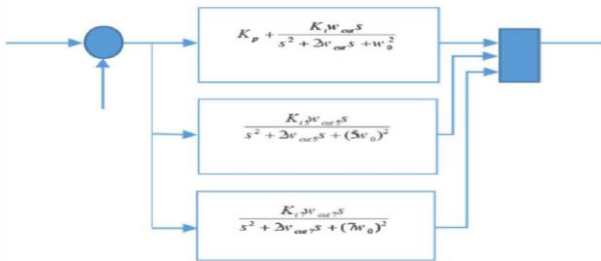

Figure 4.1 PMR controller with basic, fifth and seventh harmonic component

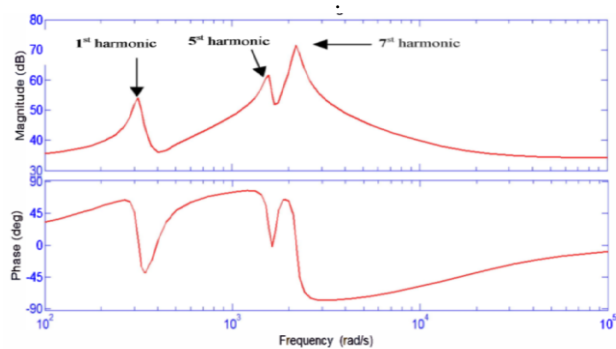

Figure 4.2 Bode plot of PMR current controller

V. SIMULATION RESULTS

In this section, the proposed control structure is simulated in MATLAB SIMULINK environment. The nonlinear load is modeled by a three-phase Universal Bridge with Series RL branch.

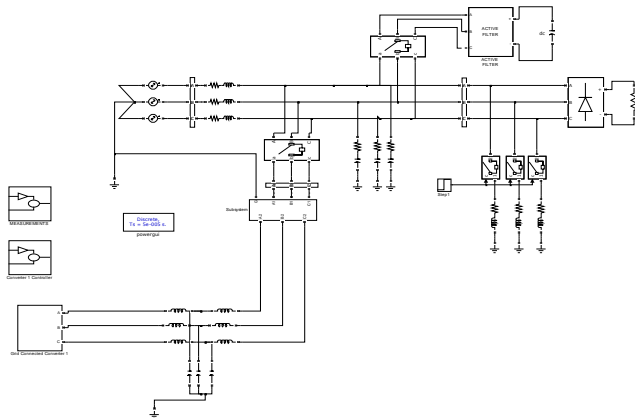

Figure 5.1: Traditional simulation with APF

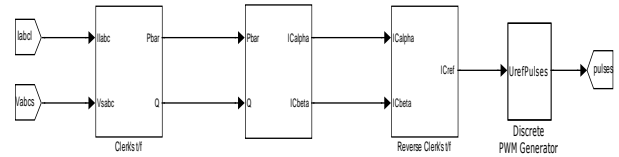

Figure 5.2: Controller Simulation Circuit

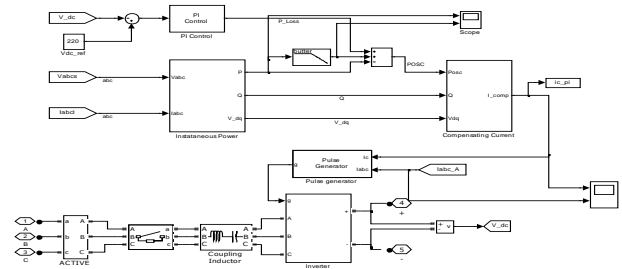

Figure 5.3: Active Power Filter of the Conventional Circuit

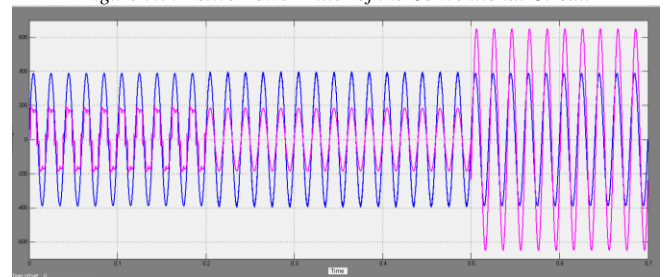

Figure 5.4: Load Voltage and Current

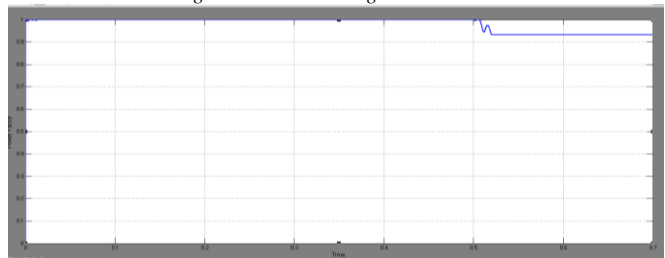

Fig5.5: Power Factor

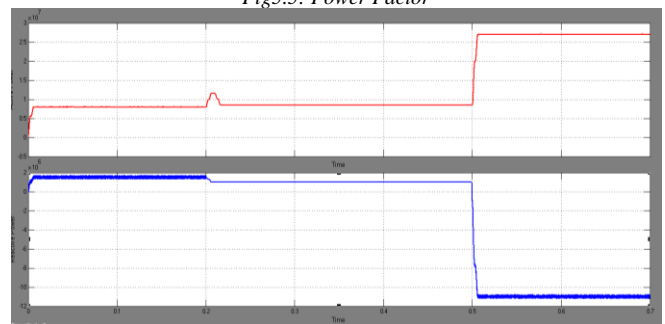

Fig:5.6 Active and Reactive Power

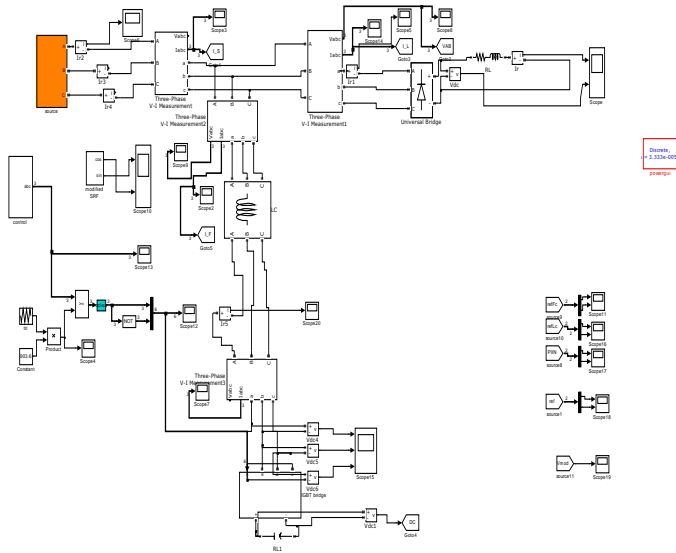

Fig 5.7: Proposed Simulation circuit with level shifted PWM

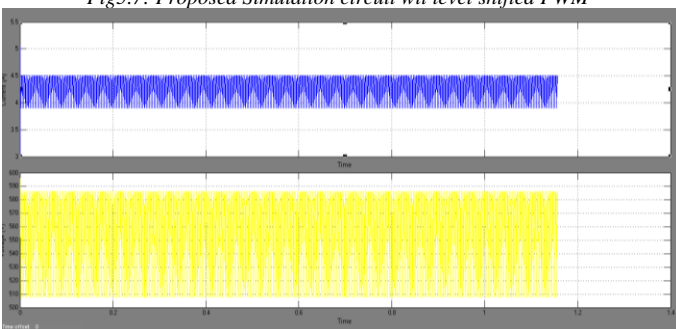

Fig 5.8: Current and Voltage

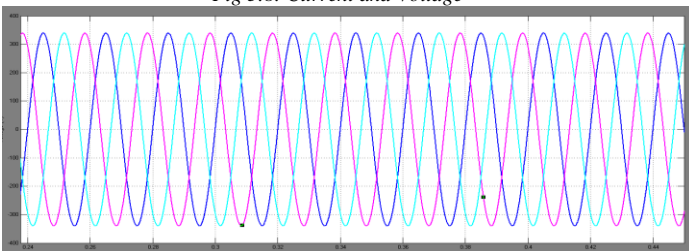

Fig 5.9: Supply Voltage

VI. CONCLUSION

Shunt APF offers better performance by improving power quality by significantly reducing the harmonic components in currents and correcting the power factor. The result of simulations performed in this work shows that synchronous reference frame detection method provides better power quality improvement. Computer aided simulations are carried out using MATLAB/Simulink simulation package, where the load is three phase twelve pulse diode bridge rectifier with R load. The harmonic filtering performance of the shunt APF is validated by a detailed THD analysis. Without APF circuit, the THD measured was 48.27% and the power factor obtained was 0.87. Then with APF circuit the THD is reduced to 8.75% and power factor is improved to 0.953. The analysed results conclude that the shunt APF topology effectively filters harmonic currents of low and high frequencies to obtain sinusoidal source current. Shunt active filters allow the compensation of current harmonics and unbalance, together

with power factor correction, and can be a much better solution than the conventional approach (capacitors for power factor correction and passive filters to compensate for current harmonics).

References

- [1] H. Fujita, and H. Akagi, "A practical approach to harmonic compensation in power systems-series connection of passive and active filters," in Industry Applications Society Annual Meeting, 1990., Conference Record of the 1990 IEEE, 1990, pp. 1107-1112 vol.2.
- [2] W. Liqiao, and W. Weiyang, "Shunt Active Power Filter with Sample Time Staggered Space Vector Modulation Based Cascade Multilevel Converters," in Power Electronics and Motion Control Conference, 2006. IPEMC 2006. CESIIEEE 5th International, 2006, pp. 1-5.
- [3] W. Lenwari, "Optimized design of modified proportional-resonant controller for current control of active filters," in Industrial Technology (ICIT), 2013 IEEE International Conference on, 2013, pp. 894-899.
- [4] H. Sepahvand, L. Jingsheng, M. Ferdowsi, and K. A. Corzine, "Capacitor Voltage Regulation in Single-DC-Source Cascaded H-Bridge Multilevel Converters Using Phase-Shift Modulation," Industrial Electronics, IEEE Transactions on, vol. 60, no. 9, pp. 3619-3626, 2013.
- [5] A. Kahrobaeian, and S. Farhangi, "Stationary frame current control of single phase grid connected PV inverters." pp. 435- 438.
- [6] D. De, and V. Ramanarayanan, "A Proportional+Multiresonant Controller for Three-Phase Four-Wire High-Frequency Link Inverter," Power Electronics, IEEE Transactions on, vol. 25, no. 4, pp. 899-906, 2010.
- [7] P. Fang Zheng, L. Jih-Sheng, J. W. McKeever, and J. VanCoevering, "A multilevel voltage-source inverter with separate DC sources for static V Ar generation," Industry Applications, IEEE Transactions on, vol. 32, no. 5, pp. 1130-1138, 1996.
- [8] W. Liqiao, and W. Weiyang, "Shunt Active Power Filter with Sample Time Staggered Space Vector Modulation Based Cascade Multilevel Converters," in Power Electronics and Motion Control Conference, 2006. IPEMC 2006. CESIIEEE 5th International, 2006, pp. 1-5.
- [9] P. Orner, I. Kumar, and B. S. Su♦jan, "Comparison of multicarrier PWM techniques for cascaded H-bridge inverter," in Electrical, Electronics and Computer Science (SCEECS), 2014 IEEE Students' Conference on, 2014, pp. 1-6.
- [10] S. Mohammadi, H. R Mosaddegh, and M. Y ousefian, "Mitigation of Switching Harmonics in Shunt Active Power Filter Based on Variable Structure Control Approach," Journal of Electrical and Computer Engineering Innovations, vol. 1, no. 2, pp. 83-88, 12/30, 2013.
- [11] M. Odavic, V. Biagini, P. Zanchetta, M. Sumner, and M. Degano, "One-sample-period-ahead predictive current control for high-performance active shunt power filters," Power Electronics, IET, vol. 4, no. 4, pp. 414-423, 2011.
- [12] R. Grino, R. Cardoner, C. Costa, x, R, and E. Fossas, "Digital Repetitive Control of a Three-Phase Four-Wire Shunt Active Filter," Industrial Electronics, IEEE Transactions on, vol. 54, no.3, pp.1495-1503, 2007.
- [13] M. Sedighy, S. B. Dewan, and F. P. Dawson, "A robust digital current control method for active power filters," Industry Applications, IEEE Transactions on, vol. 36, no. 4, pp. 1158-1164, 2000.
- [14] L. Yun Wei, F. Blaabjerg, D. M. Vilathgamuwa, and L. Poh Chiang, "Design and Comparison of High Performance Stationary-Frame Controllers for DVR Implementation," Power Electronics, IEEE Transactions on, vol. 22, no. 2, pp. 602-612, 2007.
- [15] W. Lenwari, "Optimized design of modified proportionalresonant controller for current control of active filters," in Industrial Technology (ICIT), 2013 IEEE International Conference on, 2013, pp. 894-899.