

THERMAL ANALYSIS OF CANTILEVER BEAM

Dr.Noor Alam¹ , MizraHarron Baig²

Professor¹ , Assistant professor²

Department Of Mechanical Engineering

NAWAB SHAH ALAM KHAN COLLEGE OF ENGINNERING & TECHNOLOGY

NEW MALAKPET , HYDERABAD-500 024

Abstract—

This study focuses on the structural and modal analysis of carbon steel members subjected to heat loading. Calculations for both the cantilever and the fixed-end components are performed. For members with various cross sections but a same cross section area, deflection and stress were studied. A lack of mechanical forces may lead to heat stresses and deformations in structural components. Temperature variations may have an effect on mechanical components. These findings provide light on how temperature changes affect structure.. The material expands as the temperature rises, which may have an impact on its structural integrity. It's possible that you'll create hazardous designs if you don't consider the implications of constrained parameters. This has a substantial influence on the structural performance of structures exposed to high temperatures. The investigation's primary objective is to measure the deflection and stress in the beam. Analyses are done by using ANSYS, which is followed by real-world testing. ANSYS is used to explore how the structure's mode shape and frequency change as the temperature increases.

INTRODUCTION

Deflection, Mode, Mode shape, and Modal analysis are all included in the index. The expansion of a material due to thermal stress is called thermal expansion.

Temperature variations have an impact on almost all mechanical components. Components expand and contract as a result of temperature changes. Thermal stresses are caused by the restriction of the member's expansion. Temperatures over a certain threshold weaken the structure's elasticity and stiffness. Studying how various sorts of restrictions affect a member's response to temperature and mechanical stresses has helped researchers better understand mechanical structure behaviour. Mechanical and thermal stress are applied to a component, and the results are analysed. It was shown that mechanically loaded members with varying restraining support conditions (ASME SA36) were affected by heat loading [9]. Cantilever and supported beams with a point load under thermal loading are studied in this study. When the temperature changes, researchers examine how a loaded beam deflections and slopes in response.

ANSYS [5] is used to do the FEA analysis. Mechanical stresses are common in real-world constructions because of applied loads and constrained thermal expansion. Structural mechanics theories were used in the development of all analytical formulations. Temperatures may influence the behaviour of structures when they are linked to one

$$\epsilon_{\text{Total}} = \epsilon_{\text{Thermal}} + \epsilon_{\text{Mechanical}} \quad (1)$$

another. This basic relationship affects everything in life.

Structural member strain is the sum of the thermal and mechanical strains in the material. Mechanical strain is the single factor that determines the stress in a structure. When thermal stresses are completely restricted, thermal stress will be generated. The member's cross-sectional area will influence its mechanical stress. The bending stress of rectangular and I-section members with the same cross sectional area of 80 mm² are compared to determine the influence of cross section.

NOMENCLATURE

σ = Uniaxial Stress,

MPa P = Load,

N A = Area of Cross section,

mm² T = Temperature,

α = Coefficient of thermal expansion ,

Young's Modulus,

MPa δ = Deflection,

μ = Poisson's Ratio ρ = Density,

ϵ = Temperature Strain γ_m = Lateral
deflection due to temperature change,

mm⁴ I = Moment of Inertia,

mm⁴ L = Length ,

mm b = Breadth,

mm h = Height, mm

LITERATURE REVIEW

As part of this review, an Artificial Neural Network (ANN) is employed as an indicator of cantilever beam structural issues. Structures having a lower mass may have a lower natural frequency. To guarantee that the structure is running at its optimum level, periodic frequency measurements are necessary. Despite the difficulty of determining frequency in dynamic and complex systems, several articles were analysed for symptoms of structural degradation. Among the topics covered in this book are things like how deep the fracture is and where exactly it is located. Artificial neural networks and rapid Fourier transformations have been utilised in a number of articles to evaluate natural frequencies and identify damage. Vibrations, finite element analysis, and artificial neural networks were used to identify structural damage (ANN).

A Computer Aided Design (CAD) Micro Cantilever Beam for Vapour Detection.

Micro cantilever beams of various sorts and materials are examined in this research. For each micro cantilever beam shape, it is designed, analysed, and simulated. ComSOL In both structural mechanics and chemical module modelling, multiphysics is a valuable tool. Using several beam structures and the corresponding Eigen frequencies, examine the results. Adsorption of reactive species in laminar flow is accomplished by using chemical pillars from surface reactions and deposition processes in the flow cell.

Jib Crane Cantilever Beam Structural Analysis

In this research, a conventional I section cantilever beam is exposed to an equally distributed force (the self-weight) and a concentrated load at the free end. Lateral torsional buckling is the primary failure mode of "slender" beams, and it dictates their design. Online forms and resources are also included in this research. In order to ensure the validity of the findings, finite element analysis and experiments are used to verify the results. An optimization approach is used to find the best possible solution from a number of different designs that are on the table. Samples weighing between 250 and 500 kilogrammes and measuring 3 to 6 metres in length were evaluated for web and flange thicknesses. Structural analysis looks at how varying section sizes effect free-end point loads and uniformly distributed cantilever loads when it comes to structural performance. Additionally, the cross-sectional cross-section of the cantilever beam's web affects its ability to resist buckling in the lateral direction.

Tapered Beam Vibration Analysis

Beams may be classified as either straight or curved, based on the geometric design of their form. Non-uniform beams may be used in architecture, robotics, and other innovative engineering applications because they evenly distribute weight and strength. In order to withstand dynamic forces like wind and earthquakes, these buildings must be built to exacting standards. Understanding a structure's fundamental frequencies and mode shapes is critical. The Euler cantilever beam's natural frequencies may be calculated by solving for the equation of motion. Galerkin's technique and weighted residuals were used to generate a finite element model. For a broad variety of taper ratios, natural frequencies and mode shapes may be found. The natural frequencies and mode shapes of different taper ratios are compared.

Temperature increase

This section is designed to provide a fast overview.

Changes in the volume and surface area of matter occur as a consequence of the expansion of matter as a result of rising temperatures.[1]

For any given material, molecular kinetic energy is inversely related to temperature. When heated, molecules have more kinetic energy. As a result of this, atoms and molecules vibrate more often and maintain a larger average distance between them. As temperatures rise, only a few materials are able to compress. This is a one-of-a-kind event (see examples below). A material's coefficient of thermal expansion may be found by dividing the temperature change by the relative expansion (also known as strain).

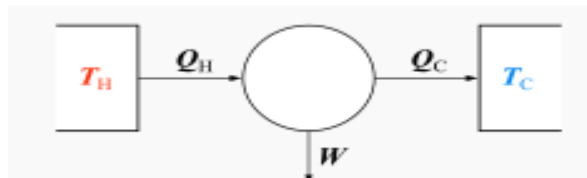

Temperature increase

Solids Expanding

The body's capacity to expand and contract must be taken into account when calculating thermal expansion. The expansion or strain caused by a rise in temperature may be calculated using the appropriate coefficient of thermal expansion.

Internal tension may be caused by changes in temperature in a body that is unable to expand. When a body is allowed to expand, the elastic or Young's modulus may be used to determine the strain that would result and the amount of tension needed to bring that strain to a halt. The impact of ambient pressure on an object's size is not necessary in the case of solid materials.

Thermal expansion coefficients of most standard engineering materials are either constant or average over the temperature range in which they are expected to fulfil their function. This is necessary to make accurate calculations.

In a straight line.

Thermal expansion may cause a rod's length to fluctuate.

not volume, but length, is what linear expansion refers to (volumetric expansion). CLTE provides an approximation of the relationship between temperature change and object length change due to thermal expansion (Coefficient of Linear Thermal Expansion). As the temperature rises, the thermal expansion factor increases. If pressure has no impact, we may write:

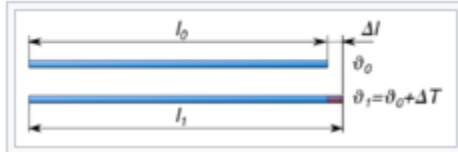

Thermal expansion may cause a rod's length to fluctuate.

Rubber spacers are required for metal-framed windows.

Rubber tyres must be able to function correctly in all temperatures since they are sensitive to both passive and active heat from the road surface and mechanical flexing and friction.

Long, straight runs of metal hot water heating pipes are not recommended.

To minimise sun kink, large constructions like trains and bridges must have expansion joints.

Cold car engines operate poorly because of the inefficiently high spacings between components until the typical operating temperature is reached.

A gridiron pendulum's pendulum length is increased by using a combination of metals.

When it's hot outside, a power line sags; when it's cold, it's taut. This phenomenon is caused by the tendency of metals to expand when heated.

When a plumbing system experiences thermal expansion, expansion joints bear the brunt of the stress.

Precision engineering is almost always required to account for thermal expansion. It is possible that the sample will move out of the scanning electron microscope's field of view if the temperature changes by only one degree.

When the volume of a liquid changes with temperature, only one direction of flow is possible via a thermometer that uses a liquid, such as mercury or alcohol.

Because the coefficients of thermal expansion of the two metals differ, a bimetallic strip is required.

Internal Surface Heat Loads

Both interior and exterior surfaces may be heated with Creo Simulate. Heat loads may be applied to two types of interior surfaces:

The inner region of a mated surface ab, or the point at where two surfaces meet.

The bottom internal surface of a volume.

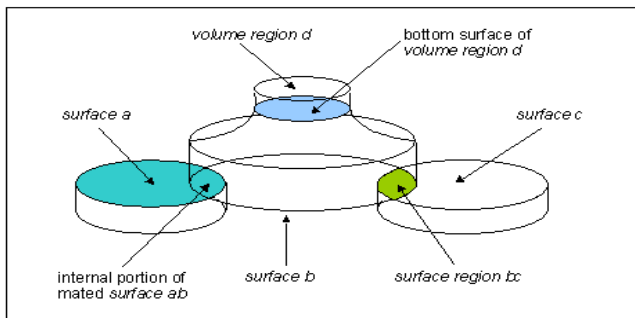

The mated segment of surface a's heat load would be calculated using surface an as a reference.

To determine the quantity of heat being transferred from the mated surface, an initial surface area would be created.

Beam

Introduction

In order to support weight, a beam is a structural component that may bend. The bending moment is the result of the interaction between the beam's weight, span, and the forces acting on it from the outside. Cross-sectional form, length, and material are used to categorise beams.

This includes truck and vehicle frameworks, machine frames, as well as other mechanical or structural systems that use beam constructions.



Beam cross section

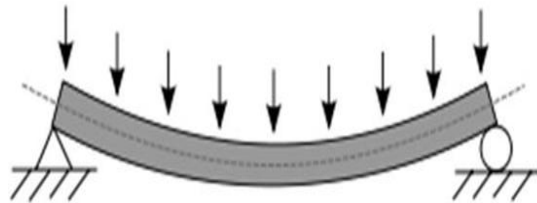

Metal, stone, or wood-metal combinations may also be used to construct beams, which are often constructed from squared timber. Thus, beams may sustain horizontal loads, such as earthquake or wind loads, as well as compression, like a collar beam, which can be employed to support the rafter thrust. When loads are carried from beams to walls, girders, and columns, a domino effect is set into motion. Joists may be supported by beams in light-frame constructions.

A beam in carpentry may be referred to as either a plate or a beam depending on the context.

In certain cases, the kind of support a beam possesses might assist categorise it.

The forms and widths of beams used in engineering may vary greatly:

"Simply supported" beams may be freely rotated and have no moment resistance, which is why they're called that.

The term "fixed beam" refers to a beam that cannot be turned since it is supported at both ends.

On one end, overhangs extend beyond the support of a fundamental beam.

On each side of the beam, there are two protruding ends.

The beam must have more than two points in order to be considered "continuous."

Cantilever beams have just one end supported by a structure.

In order to define a truss, you need to connect a cable or rod to the beam.

Moment of Inertia:

The "I" in the beam formula stands for the two-moment-of-area. An inertia or "moment of inertia" may be calculated by multiplying two tiny patches of neutral axis area by $(dA \cdot r^2)$ and $(dA \cdot r^2)$. Consequently, the distance squared of each section's area from the axis is included in the overall area. The more stiff the beam is when bent, the greater I grows when utilising a certain material.

SHAPE IN GENERAL:

Reinforced concrete beams should have an I or H cross section rather than a rectangular cross section. Additionally, the beam's total stiffness is increased by placing extra material away from its neutral axis.

You can only bend it in the I-direction if you use this method. beam's This results in a decrease in efficiency as compared to leaving the beam straight. Because it can bend in any direction, no matter how far, a cylindrical shell or tube is the most efficient type of 2D geometry. I or broad-flange beams, on the other hand, should only be bent in a single direction.

The beam deflects less when the same stress conditions and cross-sectional area are applied (volume of beam per length). "Effective" refers to something like this.

Various construction methods, such as angles, channels, and tubes, may be used if necessary.

An example of a thin-walled beam may be seen here:

The use of thin-walled beams in the construction of structures is an excellent substitute (structure). Panels are piled on top of one another in thin-walled beams to generate closed or open cross sections (structure). Tubes are available in a variety of shapes and sizes for use in closed components. Structures like I-beams, T-beams, and L-beams may have free spaces. Since the bending stiffness per unit cross sectional area of thin-walled beams is greater than that of thick-walled rods or bars, they are often used in structural applications. This technique allows for the construction of strong buildings with a little amount of material. Composite laminates may be attached to thin-walled beams. Librescu pioneered the use of thin-walled beams and composite laminates.

CANTILEVERS' POWER OUTLETS

Two separate types of cantilevers are the vertical and the horizontal cantilevers (typically horizontal). Trusses or slabs may also be used to construct cantilever constructions. When the cantilever is subjected to moment and shear stresses, it is pushed against the support.

Cantilever construction, as opposed to systems supported at both ends with loads imposed between the supports, permits overhanging buildings without external bracing, such as a post and lintel system's simply supported beam.

APPLICATIONS:

A few notable examples of cantilever architecture are Bridges and balconies built using cantilevers (see corbel). Since each cantilever supports one end of a centre portion, it is normal practise to manufacture cantilevers in pairs. The Forth Bridge in Scotland is a good example of a bridge of this kind in motion.. The jetty or forebay in

traditional timber-framed dwellings is a cantilever. Log building known as the "cantilever barn" has a long and storied history in the southern United States.

In the construction sector, cantilevers are often used. If the half-built building generates a cantilever, the whole construction does not have the same result. A considerable advantage accrues when temporary supports (falsework) cannot be used to hold the building in place while it is being constructed (e.g., over a busy roadway or river, or in a deep valley). When the Navajo Bridge's cantilever spans are jacked apart before they are rejoined, this procedure emphasises the compression of the cantilevers. Cantilevers play a significant part in the construction of cable-stayed bridges. Rather of being built in pieces, box girder bridges are typically built as a single unit. A cantilever bridge may span both directions with a single support.

Torque and rotational equilibrium are used to keep these structures stable.

Frank Lloyd Wright used cantilevers to construct Fallingwater's massive balconies. The East Stand at Elland Road Stadium was the world's largest cantilever structure when it was completed in 2013. Spectators at Old Trafford Football Ground's cantilever top won't be obstructed by any structural supports. There were many similarities between the roof of Miami Stadium and this one. Newcastle United Football Club plays on Europe's largest cantilever at St James' Park in Newcastle-upon-Tyne.

Radio towers and wind-resistant chimneys are examples of cantilever design in use today.

The following are the positives and disadvantages:

Advantages

Because there is no counterweight on the other side, it is not necessary (probably the main reason you would ever have a cantilever beam).

A negative bend might be produced as an alternative to a positive curve. The backspan of a cantilever will bend in the same direction as the cantilever when a uniform weight is applied.

Disadvantages

Deceleration was a big factor.

The outcome is virtually always bigger moments.

Another method is to utilise a fixed support or backspan and look for an uplift in the support at a greater distance away.

An overview of computer-aided design (CAD).

Many innovative innovations and technologies have been patented in our industrial civilization throughout the years. The digital computer has had a much greater influence on the economy than any previous technological advancement.

In the drawing office, computers are rapidly being utilised to design and define technical components. There are several subcategories of CAD, but "computer-aided design" (CAD) is the most often used. In computer-aided design (CAD), interactive computer graphics systems are the most often used tool (CAD). In the field of mechanical design and geometric modelling, the use of computer-aided design approaches has had a considerable influence.

There are several good reasons for using a CAD system to support the engineering design function:

- To increase the productivity

- To improve the quality of the design
- To uniform design standards
- To create a manufacturing data base
- To eliminate inaccuracies caused by hand-copying of drawings and inconsistency between
- Drawings

INTRODUCTION TO PRO/ENGINEER:

Pro/ENGINEER is the industry's standard 3D mechanical design suit. It is the world's leading CAD/CAM /CAE software, gives a broad range of integrated solutions to cover all aspects of product design and manufacturing. Much of its success can be attributed to its technology which spurs its customer's to more quickly and consistently innovate a new robust, parametric, feature based model, because the Pro/E technology is unmatched in this field, in all processes, in all countries, in all kind of companies along the supply chains. Pro/Engineer is also the perfect solution for the manufacturing enterprise, with associative applications, robust responsiveness and web connectivity that make it the ideal flexible engineering solution to accelerate innovations. Pro/Engineer provides easy to use solution tailored to the needs of small, medium sized enterprises as well as large industrial corporations in all industries, consumer goods, fabrications and assembly, electrical and electronics goods, automotive, aerospace etc

Advantages of Pro/Engineer:

It is much faster and more accurate. Once a design is completed. 2D and 3D views are readily obtainable.

The ability to incorporate changes in the design process is possible.

It provides a very accurate representation of model specifying all other dimensions hidden geometry etc.

It provides a greater flexibility for change. For example if we like to change the dimensions of our model, all the related dimensions in design assembly, manufacturing etc. will automatically change.

It provides clear 3D models, which are easy to visualize and understand.

ProE provides easy assembly of the individual parts or models created it also decreases the time required for the assembly to a large extent.

Methodology

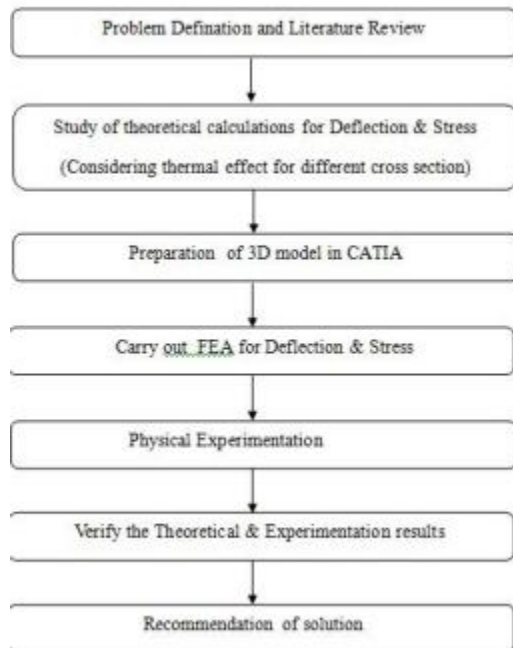

Material Specification

Material : Structural Carbon Steel. ASME SA36. [9]

Young's Modulus (E) = 200 GPa

Poisson's Ratio (μ) = 0.26

Density (ρ) = 7850 Kg/m³

Tensile Strength = 400-500 MPa

Yield point Strength = 250 MPa

Coefficient of Thermal Expansion (α) = $12 \times 10^{-6} / ^\circ\text{C}$

Temperature ($^\circ\text{C}$)	20	100	200	300	400	500
Young's Modulus (GPa)	200	200	189	168	147	126

Moment of Inertia calculation for rectangular and I-Section

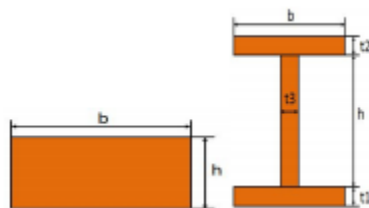

Rectangular and I-Section

a) Rectangular Section

$$I = \frac{bh^3}{12} \quad (2)$$

b) I-Section

$$I = \frac{bd^3}{12} - \frac{(b-t_3)(d-2t_1)^3}{12} \quad (3)$$

Stress and deflection due to temperature change

a) Cantilever Member

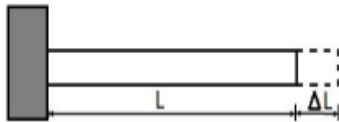

Thermal expansion of Cantilever member

Change in the dimensions of cantilever member due to increase in temperature is given below

$$\text{Change in length } (\Delta L) = \alpha L \Delta T \text{ mm} \quad (4)$$

$$\text{New length } (L_e) = L + \Delta L = L(1 + \alpha \Delta T) \text{ mm} \quad (5)$$

$$\text{New breadth } (b_e) = b + \Delta b = b(1 + \alpha \Delta T) \text{ mm} \quad (6)$$

$$\text{New Height } (h_e) = h + \Delta h = h(1 + \alpha \Delta T) \text{ mm} \quad (7)$$

Stress does not induce in member because of free expansion.

Fixed member

For fixed member, axial expansion is zero. Which induces thermal stress inside body because of restraining force. Thermal stress causes lateral deflection similar to buckling. Lateral deflection is calculated using relation

$$\text{Lateral deflection } (y_m) = \frac{2L}{\pi} \sqrt{\epsilon + \frac{\epsilon^2}{2}} \text{ mm} \quad (8)$$

$$\text{Temperature Strain } (\epsilon) = \alpha \Delta T \quad (9)$$

$$\text{Restraining Force} = EA\alpha\Delta T \quad (10)$$

$$\text{Axial Stress} = E\alpha\Delta T \quad (11)$$

Stress and Deflection of member with point load

Cantilever member

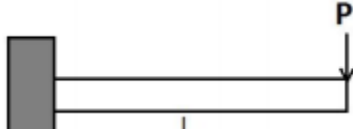

Cantilever member

$$\text{Deflection } (\delta) = \frac{PL^3}{3EI} \text{ mm} \quad (12)$$

$$\text{Bending Stress } (\sigma_b) = \frac{My}{I} \text{ MPa} \quad (13)$$

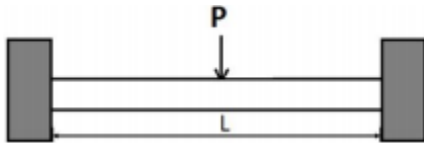

Fixed Member

$$\text{Deflection } (\delta) = \frac{PL^3}{192EI} \text{ mm} \quad (14)$$

$$\text{Bending Stress} = \frac{My}{I} \text{ MPa} \quad (15)$$

Combined Mechanical and thermal loading

$$C_{\text{total}} = C_{\text{thermal}} + C_{\text{mechanical}} \quad (16)$$

Illustration 1 shows a structural carbon steel (ASME SA36) component with a point load of 1000 N. It has a cross-sectional area of 80 mm² and is 400 mm in length. Determine the tension and deflection of a cantilever member with a rectangular cross section at each of the following temperatures: Temperatures up to 200°C

The cantilever component of the I-section

Structural member with reticular sections

An I-sectioned, non-moving component 40 mm b and 20 mm h are the sectional measures. B=46mm, h=70 mm, t₁=t₂=5.2 mm, and t₃=4.6 mm in the I-section of the I-section Section IV contains all the expressions needed to run the computations and compile the results.

A cantilever component with a rectangular section

Temperature	°C	20	200	300	400	500
Young's Modulus (E)	MPa	200000	189000	168000	147000	126000
Length (Le)	mm	400	400.864	401.344	401.824	402.304
Width (be)	mm	40	40.0864	40.1344	40.1824	40.2304
Height (he)	mm	20	20.0432	20.0672	20.0912	20.1152
y	mm	10	10.0216	10.0336	10.0456	10.0576
Bending Moment (M)	N-mm	400000	400864	401344	401824	402304
Moment of Inertia (I)	mm ⁴	26666.67	26897.81	27026.88	27156.4	27286.4
Deflection (δ)	mm	4	4.223681	4.745958	5.417473	6.312844
Bending Stress (σb)	MPa	150	149.3541	148.9971	148.6413	148.2868

Temperature	°C	20	200	300	400	500
Young's Modulus (E)	MPa	200000	189000	168000	147000	126000
Length (Le)	mm	400	400.864	401.344	401.824	402.304
Flange Width (be)	mm	46	46.09936	46.15456	46.20976	46.26496
Web Height (he)	mm	70	70.1512	70.2352	70.3192	70.4032
Flange thickness (t1e = t2e)	mm	5.2	5.211232	5.217472	5.223712	5.229952
Web thickness (t3e)	mm	4.6	4.609936	4.615456	4.620976	4.626496
Total Depth (de)	mm	80.4	80.57366	80.67014	80.76662	80.8631
y	mm	40.2	40.28683	40.33507	40.38331	40.43155
Bending Moment (M)	N-mm	400000	400864	401344	401824	402304
Moment of Inertia (I)	mm ⁴	808904.1	815915.7	819830.7	823759.8	827702.9
Deflection (δ)	mm	0.131866	0.13924	0.156457	0.178595	0.208112
Bending Stress (σb)	MPa	19.87875	19.79315	19.74583	19.69869	19.65171

Table 2. Cantilever Member with I- Section

Table 3. Fixed Member with Rectangular Section

Temperature	°C	20	200	300	400	500
Young's Modulus (E)	MPa	200000	189000	168000	147000	126000
Length (Le)	mm	400	400	400	400	400
Width (be)	mm	40	40.0864	40.1344	40.1824	40.2304
Height (he)	mm	20	20.0432	20.0672	20.0912	20.1152
y	mm	10	10.0216	10.0336	10.0456	10.0576
Bending Moment (M)	N-mm	50000	50000	50000	50000	50000
Moment of Inertia (I)	mm ⁴	26666.67	26897.81	27026.88	27156.4	27286.4
Deflection due to point load (δ)	mm	0.063	0.066	0.073	0.084	0.097
Bending Stress (σb)	MPa	18.75	18.63	18.56	18.50	18.43
Temperature strain (εt)		0	0.00216	0.00336	0.00456	0.00576
Restraining force	N	0.00	328004.40	454623.74	541157.81	587315.87
Uniform Axial Stress	MPa	0	408.24	564.48	670.32	725.76
Mid span deflection due to ΔT	mm	0.00	11.85	14.78	17.22	19.36
Total Deflection (δt)	mm	0.06	11.91	14.85	17.31	19.46

Table 4. Fixed member with I-Section

Temperature	°C	20	200	300	400	500
Young's Modulus (E)	MPa	200000	189000	168000	147000	126000
Length (Le)	mm	400	400	400	400	400
Flange Width (be)	mm	46.000	46.099	46.155	46.210	46.265
Web Height (he)	mm	70.000	70.151	70.235	70.319	70.403
Flange thickness (t1e = t2e)	mm	5.200	5.211	5.217	5.224	5.230
Web thickness (t3e)	mm	4.600	4.610	4.615	4.621	4.626
Total Depth (de)	mm	80.400	80.574	80.670	80.767	80.863
Area (A)	mm	800.400	803.861	805.788	807.716	809.647
y	mm	40.200	40.287	40.335	40.383	40.432
Bending Moment (M)	N-mm	50000	50000	50000	50000	50000
Moment of Inertia (I)	mm ⁴	808904.112	815915.720	819830.699	823759.750	827702.907
Deflection (δ)	mm	0.002	0.002	0.002	0.003	0.003
Bending Stress (σb)	MPa	2.485	2.469	2.460	2.451	2.442
Temperature strain (εt)		0	0.00216	0.00336	0.00456	0.00576
Restraining force	N	0.000	328168.403	454851.055	541428.384	587609.525
Uniform Axial Stress	MPa	0.000	408.240	564.480	670.320	725.760
Mid span deflection due to ΔT	mm	0.000	11.847	14.781	17.224	19.364
Total Deflection (δt)	mm	0.002	11.850	14.783	17.227	19.367

Analysis Results for Cantilever member with rectangular and I-Section are given below

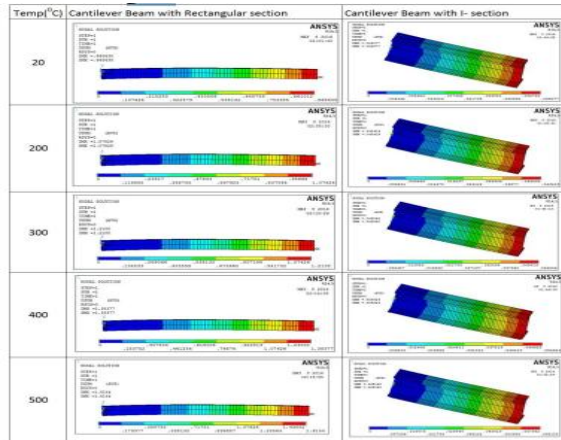

both rectangular and I-section test configurations, the deflection of the cantilever component

A load attachment and a deflection pointer are part of the test setup. A rectangular component is shown in the setup. The I-section component will be used as a template for this configuration. A 1000N point stress is applied to both the cantilever and a fixed portion at temperatures ranging from 200°C to 500°C. Below is an example of how to set up a rectangle for testing.

Cantilever Member

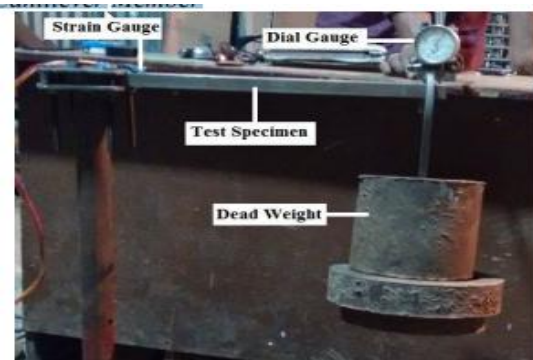

Cantilever Member Test setup

2)Fixed member

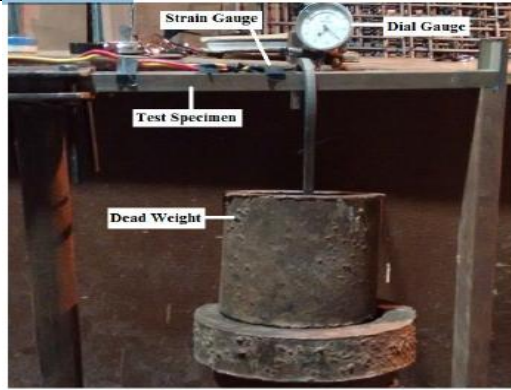

Fixed Member Test setup

Sample Calculation for stress at 200C

Reading from strain gauge

$$\text{Strain} = 3.93$$

2) Stress Calculation

By Hooke's law,

$$\text{Young's Modulus (E)} = \text{Stress/Strain}$$

$$\text{Stress} = E \times \text{Average Strain}$$

$$= 200000 \times 0.000740$$

$$= 148.05 \text{ MPa}$$

Model analysis

MODAL ANALYSIS OF CANTILEVER BEAM

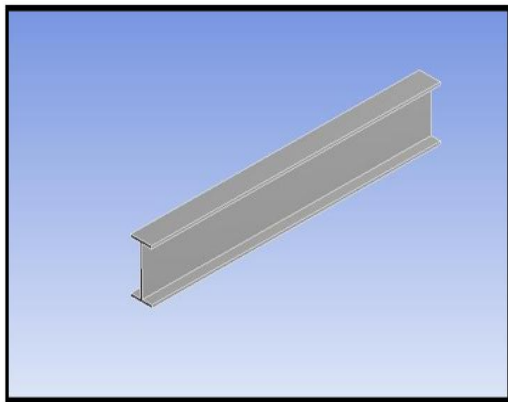

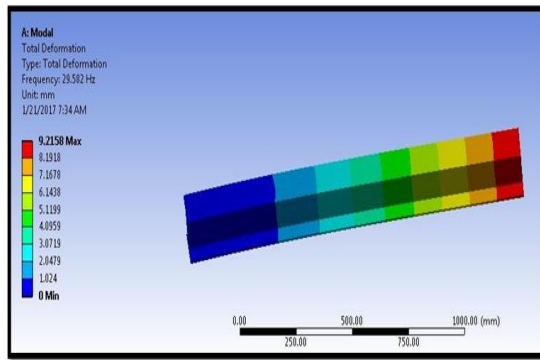

Temperature affects the mode shape and modal frequency of rectangular and I sections of cantilever members, according to ANSYS R14.5. Only Cantilever Members have access to the mode from their photographs. It's important to keep in mind that there are four sets of findings.

Section of a rectangle Results of modal analysis on a rectangular section cantilever member (Table 6).

Mode	Frequency (Hz)					
	20°C	100°C	200°C	300°C	400°C	500°C
1	102.19	102.19	98.68	93.04	87.03	80.57
2	202.89	202.89	196.52	185.28	173.31	160.46
3	633.1	633.1	604.68	570.1	533.28	493.72
4	1216.9	1216.9	1176.2	1109	1037.4	960.4
5	1465	1465	1445.2	1362.6	1274.6	1180
6	1741.9	1741.9	1637.8	1544.2	1444.4	1337.3

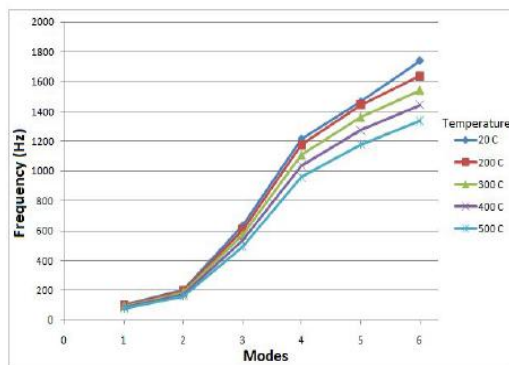

Graph between Modes and Frequency

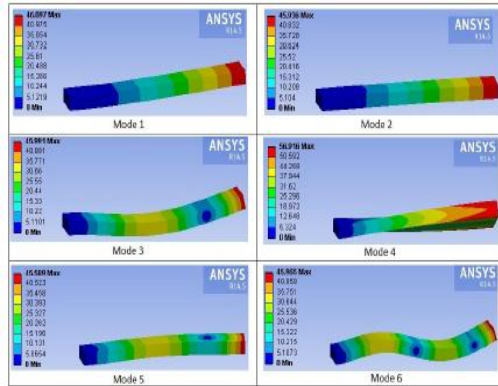

Modal Analysis for Cantilever member with rectangular section.

RESULTS AND DISCUSSIONS

The results for stress and deflection are tabulated in Section IV. Graph for temperature Vs Deflection is plotted.

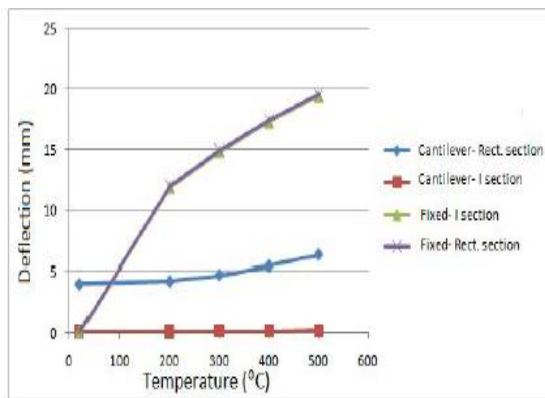

This figure is especially useful since it demonstrates how cantilever members allow the beam to expand freely across its whole length. None of this adds to the stress of the situation.

Temperature changes cause a spike in deflection.

For the same cross sectional area, the deflection of a Rectangular section member is about 30 times greater than that of an I section member.

Rectangular sections have eight times the bending stress of I-sections.

The Member's Stability

A force P is applied in the opposite direction of the thermal expansion of a stationary component, resulting in an equal and opposite axial tension. If this tension continues to grow, it will finally come to an end. If elastic-plastic materials are employed, they will continue to perform as they have in the past.

- ❖ A rise in yield stress occurs. The beam will fail before it reaches its yield stress if it has weak spots in its thickness.
- ❖ Increased deflection occurs as a consequence of temperature variations, which weaken the structure's structural integrity.

- ❖ For the same cross sectional area, rectangular section members are subjected to more than ten times as much bending stress than I-section members.
- ❖ The cantilever has less deflection than a fixed component. Forces generated by friction and heat
- ❖ Modal frequency may be reduced by raising the member's temperature. See how various members do in the 2000C charts below.

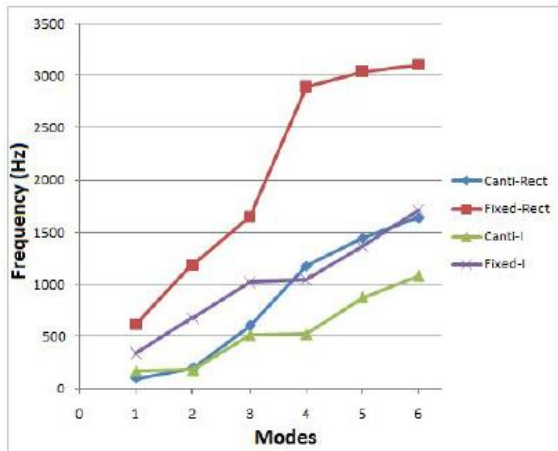

Modes Vs Frequency Graph at 2000C

Conclusion

Carbon steel structural members are verified using numerical calculations, analysis, and testing. Thermal stress and deflection data suggest that the structure's performance is deteriorating. Structures are subjected to both mechanical and thermal pressures. Aeroplane wings and temperature-changing heating systems might benefit from this new technology. According to the results of the studies, they're in accordance with expectations. The final product's quality is unaffected by flame heating. Other structural components with different cross sections may be examined in the future. Excellent for finding the optimum spot to engage in a certain activity. It may be necessary to put forth more effort to spin a shaft, for example

REFERENCES

- [1] Warren C. Young, Richard Budynas, "Roark's Formulas for Stress and Strain," 7th Edition, New York McGraw-Hill, 2002. Pp. 125-266.
- [2] John Case, Lord Chilver, Carl T.F. Ross, "Strength of Materials and Structures" Fourth edition published in 1999 by Arnold, a member of the Hodder Headline Group, 338 Euston Road, London NW1 3BH, pp.424-457. Journals & Papers:
- [3] A.S. Usmani, J.M. Rotter, S. Lamont, A.M. Sanad, M. Gillie "Fundamental principles of structural behavior under thermal effects" Fire Safety Journal 36 (2001) 721-744, 22 March 2001
- [4] Hemangi K. Patade, Dr. M. A. Chakrabarti "Thermal Stress Analysis of Beam Subjected To Fire" Int. Journal of Engineering Research and Applications, Vol. 3, Issue 5, Sep-Oct 2013, pp.420-424
- [5] C.Crosti. "Structural Analysis of Steel Structures under Fire Loading." Acta Polytechnica Vol. 49 No. 1/2009, 2009
- [6] Chung Thi, Thu Ho. "Analysis of thermally induced forces in steel columns subjected to fire." 2010.
- [7] Choe, Lisa, and A. H. Agarwal, Anil, Surovek, Andrea Varma. "Fundamental Behavior of Steel Beam-Columns and Columns under Fire Loading." J. Struct. Eng. 2011.137:954-966., 2011.

Journal of Science and Technology

ISSN: 2456-5660 Volume 5, Issue 05 (SEP-OCT 2020)

www.jst.org.in

DOI:<https://doi.org/10.46243/jst.2020.v5.i05.pp162-180>

[8] GH. Rahimi & AR. Davoodinik 'Thermal behavior analysis of the functionally graded Timoshenko's beam' - *IUST International Journal of Engineering Science*, Vol. 19, No.5-1, 2008, Page 105-113 Standards:ASME SA36 Carbon Structural Steel Plates-2007.