

Utilization of IoT and Image Processing to Create a Smart Vehicle Registry

Dr.B. Bhaskar Reddy¹, P. Imran Khan², Dr. B. Dhananjaya³
Professor^{1,3}, Assistant Professor²
Department of Electronics and Communication Engineering
Bheema Institute of Technology and Sciences, Adoni-518301.^{1,2,3}

To Cite this Article

Dr.B. Bhaskar Reddy¹, P. Imran Khan², Dr. B. Dhananjaya³ Utilization of IoT and Image Processing to Create a Smart Vehicle Registry”, *Journal of Science and Technology*, Vol. 06, Issue 06, Nov-Dec 2021, pp.:31-40.

Article Info

Received: 12-11-2021

Revised: 22-11-2021

Accepted: 02-12-2021

Published: 15-12-2021

Abstract: Everything is being automated in the contemporary technological age because of many technologies. An automated Smart Vehicle Registry with zero human intervention is constantly needed. With the help of a single automated system, RFID (Radio Frequency Identification) and Image Processing, a vehicle and its driver may be registered as they enter a designated zone. Various efforts in the fields of RFID and image processing are reviewed in this article. The proposed system consists of an RFID system that can be used to scan the person driving the vehicle, and Image processing system that includes a camera and an open-source library to scan and record the vehicle registration plate number, and a front end that manages the input and output flow of the system. The system described in this work is designed such that analysis of the output data may be conducted quickly and simply. Additionally, this article analyses the numerous results and future tasks that may be done to enhance the system in detail.

Keywords: RFID, MFRC522, OCR, Arduino, Jumpers, BreadBoard, Servomotor, IDE.

I. INTRODUCTION

Using an automated mechanism, the Smart Vehicle Registry keeps track of when a vehicle enters and leaves a designated area. RFID (Radio Frequency Identification) technology and image processing are used to create this system. A gate or toll environment is used to implement this system at the beginning and conclusion of a zone or area. RFID tags are read every time a person enters or departs a designated area. The zone or territory may only be entered or exited by those who have been permitted to do so. Using an Image Processing method known as OCR, the registration plate of the car with which the individual enters or departs is scanned simultaneously (Optical Character Recognition). Depending on the level of authority, the gate will either open or stay locked until both steps have been completed. Analyses can be carried out quickly, any fraudulent submissions may be spotted and the appropriate steps are taken. Using data analysis, it is possible to uncover useful information and trends that will aid in system development.

II. LITERATURE SURVEY

Numerous scientists and engineers have created and integrated several technologies to create an automated system that allows users to authenticate and analyse data. RFID and Arduino have been used by Orji et al [1] to construct an Automatic Access Control System that restricts and authorises access. To ensure that a person's RFID tag is authenticated after being scanned by an RFID reader, the reader compares the tag's unique ID (UID) to a database entry that lists all approved UIDs. The individual is either granted permitted access or denied it based on the results of a match. An RFID reader, a tag, plus a few communication devices like an Arduino board and a computer are all that is needed to get this system up and running, and the tag and database may be configured using these tools. Xiaoxu et al. [2] conceived and implemented an intelligent access control system for offices [1.]. This approach restricts entry to an office to those who have been granted permission to do so. A member of the workforce who want to join the workplace is required to verify their credentials beforehand. Employees use a scanner to read their RFID tag as he enters the building. The electronic clock reacts with a voice or an alarm after it has been scanned. To open

the gate, an electronic lock unlocks and a voice from the gate states that entry has been given or an access tone [2] happens. Unless approved, the electronic lock will stay closed and an alert will sound. Using RFID readers and tags, an electronic lock

and magnetic gate, and communication devices, this system may be configured. A hierarchical approach to License Plate Recognition was presented by Cheng et al [3]. The automobiles are initially spotted using deep learning methods in this approach. LPR Convolutional Neural Network (LPR CNN) is then used to distinguish characters from the plates of cars that have been spotted, reducing the number of false positives [3]. Fie et al [4] suggested a robust algorithm for detecting and recognising licence plates based on a combined feature extraction model and BPNN. Low-light conditions and complex backdrops are no barrier to this system's versatility. Conventional preprocessing begins by increasing contrast and filtering out distracting elements from the picture. Integral projection is then used to locate the licence plate's location. To fully recognise licence plate characters, the vectors are trained using BPNN, followed by feature extraction. Three sets of feature combinations were used in the design of this product.

METHODOLOGY

Using an automated system, a vehicle's entrance and departure into a designated area are recorded. The initial step of the system is to verify the driver's identity by scanning the driver's RFID tag using the MFRC522 RFID reader. A responsive display of the driver's data occurs if access is authorised. The registration plate of the card is scanned at the same time as the first step. Scanners read and store the plate's information digitally on the front end. The gate opens and the car is permitted to pass through if the access is approved and the plate recognition is complete. The gate doesn't open if the access is refused. Below is a diagram of the full process:

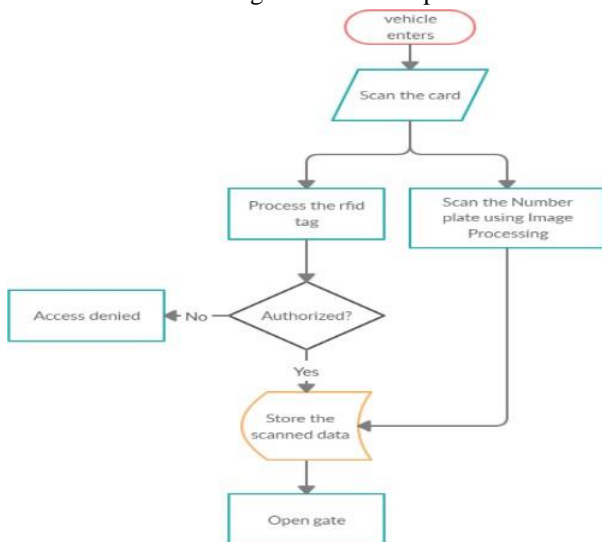
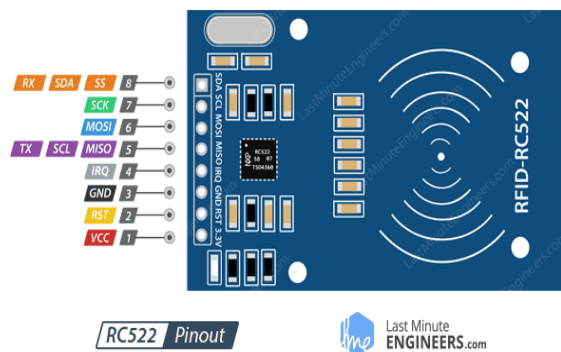

Fig.1.Implementation steps of the proposed system



III. RFID TECHNOLOGY

The initial step of the project is to use RFID technology to verify the identity of the individual entering a designated area or zone.

A. Hardware Overview

Arduino Uno is used to controlling the servo motor, which is to the breadboard through an Arduino Uno's jumper wires. To use the MFRC522 RFID reader, the Arduino board is linked to the MFRC522 RFID reader using the recommended pin

arrangement. The Arduino Uno Board is also linked to the servo motor.

RFID Tag: RFID tags employ radio frequency technology to send and receive data from an RFID reader. By employing an antenna and a microprocessor, it communicates by reading data from smart barcodes. Passive RFID tags function using electromagnetic energy broadcast from an RFID reader, while battery-operated RFID tags incorporate an integrated battery as a power source.

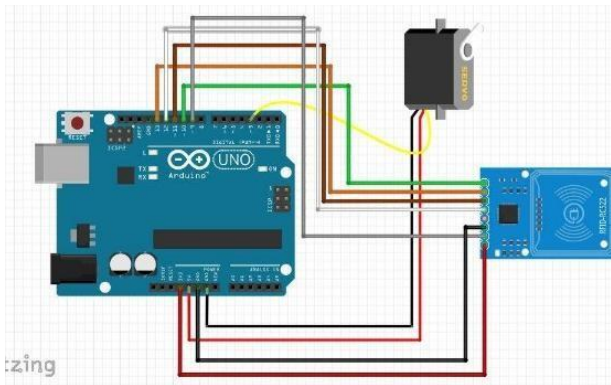

Fig.2.CircuitDiagramofRFIDTechnology



Fig.3.RFIDTags

- An RFID reader module, the MFRC522 IC, is MFRC522 IC. A 13.56MHz electromagnetic field is generated by this Reader module, which interacts with RFID tags. Serial Peripheral Interface (SPI) and I2C/UART protocols [5] are additional options for the reader. There is an interrupt pin on the module. The module's operational voltage ranges from 2.5V to 3.3V.

Fig.4.MFRC522 IC Layout [5]A

A microcontroller board with digital and analogue inputs and outputs, Arduino Uno is an open-source microcontroller. In all, there are 14 digital I/O pins and 6 analogue I/O pins on the board. It is the first in a series and maybe supplied by USB or an external power source ranging from 7 to 20 volts. The STK500 protocol was used by the Uno.

Electrical equipment used to spin an item at a precise angle is known as a "servo motor."



Fig.5.Arduino Uno SMRR3 [6]



Fig. 6.ServoMotor [7]

[7]. When the output signal is compared to the input signal, the system is said to be a closed-loop since it employs positive feedback. When the system is subjected to noise, the servo mechanism's primary job is to keep the output constant. A DC or an AC servo motor may be used. Pulse Width Modulation (PWM) is how it works.

A. Software Overview

The Arduino Board is a programming-friendly microcontroller board. Sketches may be written and then uploaded to the Arduino board using the IDE (Integrated Development Environment). C/C++ programming languages are used in Arduino's programming. There are just two functions required to run a sketch. A setup method is used to set up variables and other essential features. In a loop, real code is written and executed until the board is turned off.

B. Working of the System

The MFRC522 RFID reader module and the Servo motor are linked to the Arduino Uno. Personal information and the tag's unique identifier (UID) are written into the RFID tag using an Arduino. Uploading it to the board is completed. A person's personal information is loaded into the RFID tag, and their unique ID number (UID) is recorded into the database. Afterwards, the RFID tags are given to the persons that need them. When the MFRC522 has been configured, it allows only persons with approved RFID cards to enter the gate. As described, a driver places the RFID tag on a reader and it is an authorized entry; the personal data flows into the front-end

form. Unauthorized access ignores the data from entering into the front-end also it denies it entry into the system.

IV. VEHICLE REGISTRATION PLATE RECOGNITION

In addition to recognising the vehicle's licence plate, the front end of the system checks to see whether the access is approved, and if it is, the gate will finally open. Below is a diagram showing how this procedure works:

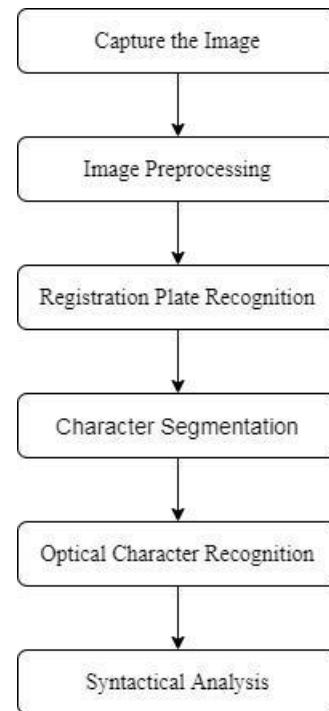

Fig. 7. The flow of Vehicle Registration Plate Recognition

A. Capturing the Image
At the location where the vehicle's licence plate may be captured, a camera is set up to capture the image. The photos are captured and sent to the front end as a live feed by this camera's sensor. For identification purposes, these photos are utilised. For a prototype, an HD camera or a computer's webcam may be utilised.

B. Image Preprocessing

When preparing an image for identification, a variety of Image Preprocessing methods are used to smooth out any imperfections. To precisely identify the characters, this approach is essential. The picture may be resized, grey scaled, or the median filter can be used.

Image Resizing: The very first process is to resize the picture since the taken image may have a different aspect ratio and may include undesired background noise. Cropping an image is an excellent option in this situation. Both manual and automated methods are available. Manual methods need a significant amount of time and effort, whereas automated methods, such as those presented by Jianzhou et al. [8], prioritise parameters such as the planted area and crop boundary.



Fig.8.ResizedImage[9]

Characters can only be discerned if the picture is scanned and turned into grayscale. It loses contrast, clarity, structure of the colour picture, and shadows in this grayscale image. By conducting RGB reduction, approximation, and addition of chrominance and luminance in a minimal amount of time, Saravanan et al. [10] presented a novel technique that retains all of the parameters listed above.

To ensure that edge detectors provide reliable results, they need a pre-processing method called a median filter to eliminate noise from the signal. Nonlinear digital filtering is what this method entails. It substitutes each item with the median of the entries immediately next to it [12] before moving on to the next one in the signal. The enhanced median filter technique introduced by Youlian et al [13] decreases noise while preserving picture clarity. The correlation of the picture is used to process the characteristics of the filtering mask over the image, as shown in this method.



Fig.9.GrayscaleImage[11]

D. RegistrationPlateLocalization

To locate the registration plate, several approaches such as edge detection, Hough transformations, binary conversion, and morphological procedures are used to extract the plate from the picture. The canny edge detector is an edge detection method that we utilise in this procedure. This operator extracts structural information from objects using a multi-stage approach. It first applies a



Fig.10. EdgeDetectedImage[16]

Gaussian filtering is used to eliminate background noise and to identify intensity gradients. Non-maximum suppression is used to remove false replies, and double thresholding is used to identify probable edges. Finally, hysteresis is used to keep track of the edges [14]. Denoising is enhanced by Jun et al[15] .'s improved Canny edge detection technique. This method enhances positioning accuracy. It alters the original method by substituting functions like Gaussian with B-Spline. The gradient histogram is utilised to determine thresholds in this approach. [15].

E. Character Segmentation

To recognize the text in an image, the characters of the text must be segmented in the image. The overall accuracy of the system depends on this step. This segmentation process is threefold. The first task is to perform line segmentation which scans the image horizontally to construct a row histogram by counting the frequency of black pixels in every row. If a position where the number of pixels in a row is entered as zero, then it represents the boundary between lines. The next task is to perform word segmentation which is similar to a line histogram except it scans the image vertically to construct a column histogram. If the number of pixels in a column is zero then it indicates the space between words. Finally, character segmentation is performed which at first finds the minimum frequency of the word, then connected component analysis is performed to find out the connected objects which help to crop the individual character.



Fig.11.Character Segmentation of Number Plate [17]

F. Optical Character Recognition

For optical character recognition, a wide variety of algorithms are available (OCR). The Tesseract class of the emgucv library may be utilised to execute OCR since we are utilising a front-end Visual Basic. From 1985 to 1995, HP built the Tesseract OCR engine, which Google has been steadily improving since 2006. The creation of this engine is based on a revolutionary method of categorization, line finding, and many other things. This method employs isotropic baseline/x-height normalisation and a two-step classification procedure, but it can also deploy an adaptive classifier for use with OCR engines. Upper- and lower-case letters may easily be distinguished using this method [18]. The process is made simpler by using a consolidated library that includes all of these functions. OpenALPR, a C++ library with Visual Studio bindings, is utilised. To identify images for various nations, OpenALPR makes use of Tesseract features and OpenCV technologies.

G. SyntacticalAnalysis

Because each nation has its unique set of requirements for registering a vehicle. Comparing national regulations using syntactical analysis is an important step. Syntactical analysis may be useful since it analyses linguistics and rules depending on the geographic location of the area where the characters are used.

V. RESULTSANDDISCUSSION

As time goes on, the RFID and the Image processing systems are integrated. However, both systems interact and pass data to an interface after functioning on their separate distinct tasks. To summarise, an RFID reader scans the RFID tag to determine whether the user is permitted before transferring the required data to the interface.

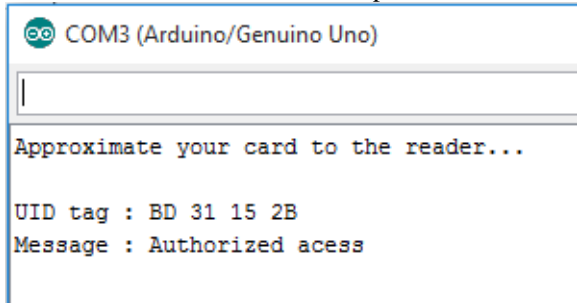

Fig.12.OutputscreeninArduinoConsole[19]

Using an open-source library called OpenALPR, an image processing system is created that uses OCR to recognise text on automobile registration plates. The OpenALPR bindings are used to implement this library in Visual Basic. Set up an identification function for the available cameras, which are preloaded into the main form as a list from which one may be picked for usage. Before using the camera, it is calibrated to match the surroundings. The number plate layouts and configurations are saved in a library for quick re-use. A camera's field of view is required for OpenALPR to identify vehicle number plates. Either a single line or many lines of text appear on Indian car licence plates. Since most automobiles have just one line of registration plates, this effort is focused on identifying the first line of those plates. Based on this standard, the camera's settings are adjusted. A table summarising the accuracy of the training and implementation phase is shown below.

Table-I:AccuracyTableofIndianPlatesvsOther Countries'Plates

Regions	Average Training Accuracy	Average Implementation Accuracy
India	92.1	91.7
Other	95.7	93.9

Countries		
-----------	--	--

After Recognizing, the text is entered into the form and the data from the RFID is also entered into the form of the Arduino board from serial communication. After both the data get entered, the data gets registered to the database along with a time stamp. There are also a few buttons inside the form for manually entering the data into the database in certain situations.



Fig.13. Output Screen of the Interface

VI. CONCLUSION

Secure workplaces benefit greatly from this Smart Vehicle Register system, which makes the job of security staff considerably simpler. A prototype was used to evaluate the proposed technology in both an indoor and outdoor setting. It was primarily designed to function in a confined corridor, such as a university, and the results are quite encouraging. The system was able to provide excellent outcomes with a reasonable degree of precision. This system was designed primarily for Indian automobiles, although that does not mean it is restricted to them. This method is also compatible with a wide range of nations. Only Indian vehicles with single-line registration plates are supported by this system. Many improvements may be made to the system soon, including the addition of support for Indian automobiles' multi-line registration plates and the addition of new features to improve the accuracy of Indian registration plates. As long as the typefaces on the plates are legible, this approach works well. To detect text that is difficult to read even with the naked eye, improvements may be made.

REFERENCES

- Orji, Everistus & Cv, Oleka & Ui, Nduanya. (2018). Automatic Access Control System using Arduino and RFID. *The Journal of Scientific and Engineering Research*. 05.333-340.
- X. Wang and Y. Wang, "An office intelligent access control system based on RFID," 2018 Chinese Control And Decision Conference (CCDC), Shenyang, 2018, pp.623-626.
- Lin, Y. Lin and W. Liu, "An efficient license plate recognition system using convolution neural networks," 2018 IEEE International Conference on Applied System Invention (ICASI), Chiba, 2018, pp.224-227.
- Xie, Fei & Zhang, Ming & Zhao, Jing & Liu, Yijian & Yuan, Xinyue. (2018). A Robust License Plate Detection and Character Recognition Algorithm Based on a Combined Feature Extraction Model and BPNN. *Journal of Advanced Transportation*. 2018.1-14.10.1155/2018/6737314.
- <https://lastminuteengineers.com/how-rfid-works-rc522-arduino-tutorial/>
- https://en.wikipedia.org/wiki/Arduino_Uno
- <https://circuitdigest.com/article/servo-motor-basics>
- J. Yan, S. Lin, S. B. Kang and X. Tang, "Learning the Change for Automatic Image Cropping," 2013 IEEE Conference on Computer Vision and Pattern Recognition, Portland, OR, 2013, pp.971-978.
- Dalarmelina, Nicole & Teixeira, Marcio & Meneguette, Rodolfo. (2019). A Real-Time Automatic Plate Recognition System Based on Optical Character Recognition and Wireless Sensor Networks for ITS. *Sensors (Basel, Switzerland)*. 20.10.3390/s20010055.
- Chandran, Saravanan. (2010). Colour Image to Grayscale Image Conversion. 196-199.10.1109/ICCEA.2010.192.
- Dalarmelina, Nicole & Teixeira, Marcio & Meneguette, Rodolfo. (2019). A Real-Time Automatic Plate Recognition System Based on Optical Character Recognition and Wireless Sensor Networks for ITS. *Sensors (Basel, Switzerland)*. 20.10.3390/s20010055.
- https://en.wikipedia.org/wiki/Median_filter
- Zhu, Youlian & Huang, Cheng. (2012). An Improved Median Filtering Algorithm for Image Noise Reduction. *Physics Procedia*. 25. 609-616.10.1016/j.phpro.2012.03.133.
- https://en.wikipedia.org/wiki/Canny_edge_detector
- Li J., Ding S. (2011) A Research on Improved Canny Edge Detection Algorithm. In: Zhang J. (eds) *Applied Informatics and Communication*. ICAIC 2011. *Communications in Computer and Information Science*, vol 228. Springer, Berlin, Heidelberg
- Mousa, Allam. (2012). Canny Edge-Detection Based Vehicle Plate Recognition. *Pattern Recognition and Image Analysis*. 5. 1-7.
- https://en.wikipedia.org/wiki/Automatic_number-plate_recognition
- R. Smith, "An Overview of the Tesseract OCR Engine," *Ninth International Conference on Document Analysis and Recognition (ICDAR 2007)*, Parana, 2007, pp.629-633.
- <https://randomnerdtutorials.com/security-access-using-mfrc522-rfid-reader-with-arduino/>