

---

## Design and Functioning of Pneumatic Belt Conveyor System

Prof. K.S. Mahajan<sup>1</sup>, Vishwadeep Budhawant<sup>2</sup>, Harshwardhan Kale<sup>3</sup>, Ashish Ghodke<sup>4</sup>, Prathamesh Bhor<sup>5</sup>

<sup>1,2,3,4,5</sup>(Department of Mechanical Engineering, NBNSOE, Ambegaon, Pune, SPPU, India)

### To Cite this Article

Prof. K.S. Mahajan<sup>1</sup>, Vishwadeep Budhawant<sup>2</sup>, Design and Functioning of Pneumatic Belt Conveyor System, Journal of Science and Technology, Vol. 06, Special Issue 01, August 2021, pp641-646: .

### Article Info

Received: 15.07.2021

Revised: 24.07.2021

Accepted: 10.08.2021

Published: 16.08.2021

**Abstract:** A pneumatic conveying system is similar to a belt or chain conveyor in terms of material handling. The primary benefit of a pneumatic conveying system is that the material is moved in a closed loop, preventing contamination of the environment and vice versa. Different parameters that determine the design of the system, such as air velocity, pressure, particle size and shape, distance to be conveyed, are described in this topic. The findings from the research on the pneumatic conveying system during the last decade that took these parameters into account are also provided. For the design of a pneumatic conveying system, there is no standard approach. As the system's configuration changes, the variables involved change as well, necessitating a change in design considerations based on the applications. As a result, in the field of pneumatic conveying systems, there is a lot of scope for experimenting. The material handling mechanism is accomplished by reciprocating a double acting cylinder that is controlled by a solenoid-operated 5/2-way DC valve that is actuated by an ON/OFF relay control system. The chain and sprocket wheel mechanism converts the linear action of the piston rod into rotational motion of the belt conveyor. We will construct a system in which the conveyor's moving roller is driven by a pneumatic cylinder in this project. The pneumatic cylinder will begin to reciprocate, and a power plate with holes will begin to roll along the sprocket. The sprocket begins to rotate unidirectionally due to the power provided by the cylinder piston and power plate. As a result, our belt conveyor begins to move.

**Keyword-** Pneumatic, Velocity, Pressure, Pneumatic Cylinder, Conveyor.

---

### I. Introduction

The study of air movement and air phenomena is known as pneumatics. The pneumatic system is employed to transmit and manage the power of the controlled gases. pneumatic systems typically used air as a fluid medium, as a result of air may be a safe, low cost and readily available fluid. It is safe for environment where an electrical spark may ignite leaks from the system components. There are various reasons for considering the use of a pneumatic system instead of a hydraulic system. Liquid exhibits greater inertia than gases. Therefore, in the hydraulic system, the weight of the oil is a potential problem. A pneumatic air engine is a double-acting pneumatic cylinder that expands compressed air to do useful work. Rather than combining fuel with air and burning it in the engine to drive pistons with hot expanding gases, the compressed air engine (CAE) employs compressed air expansion to drive pistons. To design and develop a material handling system for automation or semi automation of industries by using a pneumatic control system, which is used for low-cost automation. In a manufacturing division, material handling entails the transportation of materials. It includes loading, transporting, and unloading goods from one step of the production process to the next, A belt conveyor is consisting of an endless, flexible, high-strength belt with two end pulleys (driver and driven) that are fixed in place and are supported by rollers. Conveyor systems are reliable and efficient in material transportation and storage. The advantages of a belt conveyor are that it is simple and inexpensive to maintain, and it has a wide range of applications large loading and unloading capacity, and it can carry dense things over long distances inexpensively and efficiently, allowing relative material mobility. Abrasive, moist, dry, sticky, or unclean materials can all be transported using a belt conveyor.

### Components and Description

1. **Pneumatic Cylinder:** Pneumatic cylinders (also known as air cylinders) are mechanical devices that create a force in a reciprocating linear motion using the power of compressed gas, Energy is stored in a potential state in a pneumatic system in the form of compressed air.
2. **Conveyor Belt:** The conveyor belt consists of three cylindrical rollers operated by pneumatic actuator which serves the function of pulleys. The conveyor belt rotates over cylindrical rollers, one of the rollers is powered by a pneumatic actuator, moving the belt and the components on the belt forward. Here, the 5/2 solenoid valve receives power and signal from the electronic circuit.
3. **Sprocket:** A profiled wheel with teeth, or cogs, that mesh with a chain, track, or other perforated or indented material is known as a sprocket, sprocket-wheel, or chainwheel. Sprockets are precision clutches which positively lock to transmit torque in one direction of rotation, but are totally released in the opposite direction, as in the sketches alongside of a roller-ramp system.
4. **Solenoid Valve:** A solenoid valve is an electromechanical controlled valve. In fluidics, solenoid valves are the most often utilised control components. The valve may control a flow with a two-port design or switch flows between ports with a three-port or more-port design. Their responsibilities include turning off, releasing, dosing, distributing, and mixing fluids. They can be found in a wide range of applications. Solenoids provide rapid and safe switching, as well as high reliability, extended service life, medium compatibility of the materials used, low control power, and a compact design.
5. **Microcontroller:** : The primary and therefore the foremost criterion for choosing a microcontroller is that it must meet the task at hand efficiently and price effectively. In analysing the necessity of a microcontroller-based project we must see whether an 8-bit, 16-bit, 32-bit microcontroller can best handle the computing need of the task most efficiently. The Mega 2560 may be a microcontroller board supported the ATmega2560. it's 54 digital input/output pins (of which 15 are often used as PWM outputs), 16 analog inputs, 4 UARTs (hardware serial ports), a 16 MHz quartz oscillator, a USB connection, influence-jack, ICSP header and push button. It has everything needed to support a microcontroller, simply connect it to a computer with a USB or power it with an AC-/-DC adapter to initiate started. The Arduino Mega are powered using the USB port or via an external power supply. the facility source is chosen automatically. non-USB power can come from either an AC-/-DC adapter/wall wart or a battery. The adapter are often connected by plugging a 2.1mm centre-positive plug into the board's power jack. Leads from A battery are often inserted within the Ground and V in pin headers of the facility connector. The board can operate an external supply of 6 to twenty volts. If furnished with but 7V, however, the 5V pin could provide but five volts and therefore the board could also be unstable. If using quite 12V, the transformer may overheat and damage the board. The Mega2560 differs from all preceding boards therein it doesn't use the FTDI USB-to serial driver chip. Instead, it attributes the AT mega 8U2 programmed USB-to-serial converter.

### Objectives

The pneumatic conveyor is a brand-new design that will take the place of traditional roller conveyors. A traditional roller conveyor is powered by a motor and provides continuous motion. However, with the assistance of a pneumatic cylinder, we may perform intermediate traverse of the conveyor belt to provide step-by-step feed in a pneumatic conveyor system. The following are the basic goals that a material handling system should achieve:

- 1) Loads are picked up quickly and precisely.
- 2) Load transfer is quick and efficient, with a predetermined time interval.
- 3) Transport of loads in planned quantity.
- 4) Safe and damage-free transportation.
- 5) Accuracy in delivery to the intended location.
- 6) To design and create a pneumatic belt conveyor model.
- 7) To fabricate the prototype model of the same.
- 8) To Put the model to the test in real-world scenarios.
- 9) To develop cost effective material handling system.
- 10) To make better use of stored as well as waste compressed air.
- 11) To make replaceable system to conventional material handling system.
- 12) Also measure weight of components on conveyor.

---

### Problem Statement

To design and develop a prototype model of pneumatic belt conveyor that works on compressed air received from a storage unit which is made by combining the waste compressed air as well as unused a recirculated compressed air. Also fabricate the model using mechanical and design procedures to do the same output that is to require by objectives, i.e., to transfer small size objects from one work station to another Refuelling the compressed-air container with a low-end conventional air compressor might take up to 4 hours, but service stations' specialised equipment may fill the tanks in as little as 3 minutes.

Because of following reasons, we planned to do and design as well as fabricate the model of pneumatic belt conveyor

- Need of conveyor for material handling
- Complexity and over cost assembly of conventional electric motor conveyors.
- Avoid High cost and irregular supply of electricity.
- Use of stored as well as waste compressed air for cost effective production.
- Also measure weight of materials
- Highly Convenient Where pressurized air is available on site

### Methodology

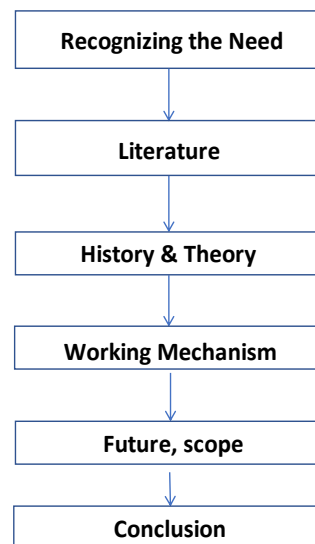

## II. Construction and Working

### Working Principal:

- In this project we used pneumatic cylinder to run conveyor belt and also measure weight of material on conveyor belt
- When we place some object on conveyor then load cell measure weight on that conveyor which can be show using colour LED's, Green LED indicate weight 0 to 3, Yellow LED indicate weight 3 to 6 and Red LED indicate weight 6 and more.

After loading an object, the conveyor automatically starts using double acting pneumatic cylinder for that sprocket and plate arrangement is there. On this plate there are small holes which can mesh with sprocket and run the conveyor.

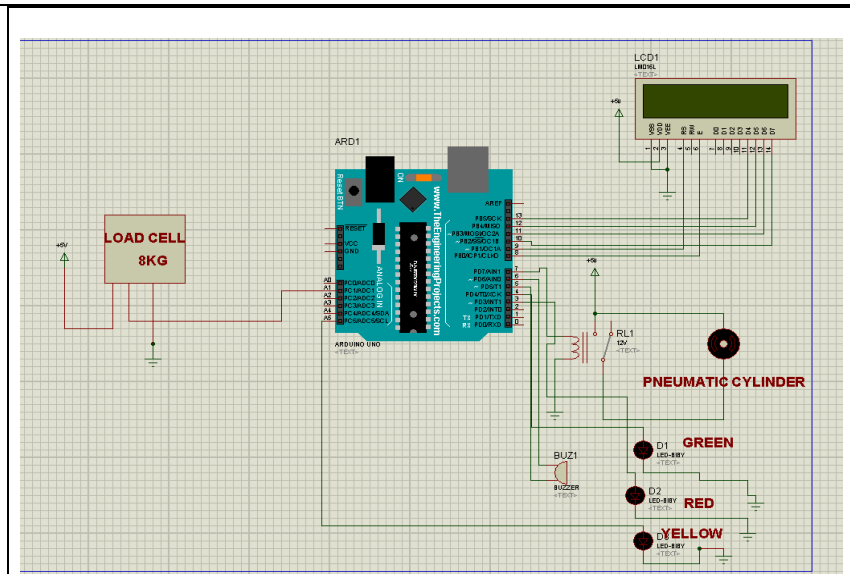

Figure 1: Circuit Diagram

**Arduino uno** as a main controller used which controls all the operations.

If Weight is more than 7kg, red led will glow and buzzer will beep for 5 sec.

If weight is below 5kg then green led will glow.

If weight in between 5kg to 8kg then yellow led will glow automatically.

And pneumatic cylinder will actuate through relay module.

All information will be displayed on LCD 16\*2 Display.

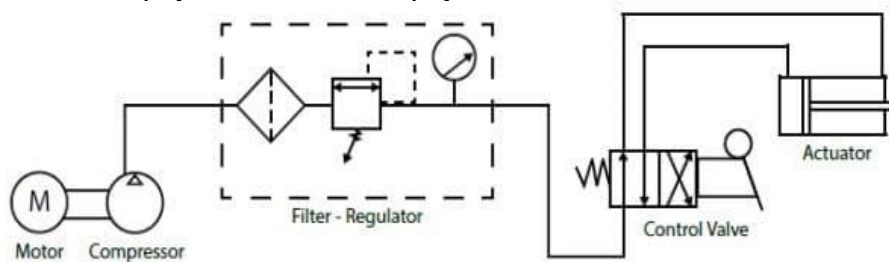

Figure 2: Major Components of Pneumatic System

### CAD MODEL

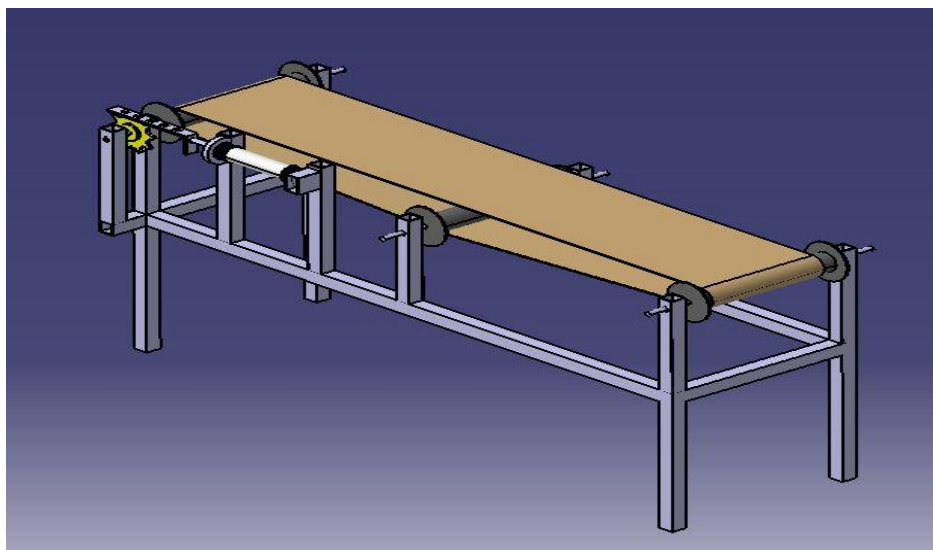

Figure 3: Isometric View

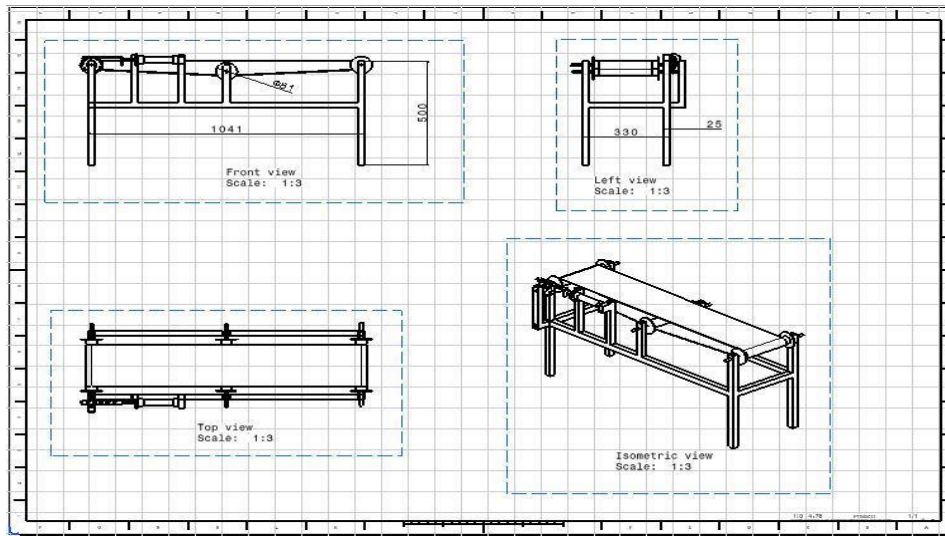

Figure 4: Drafted View

### Observation Results:

Belt conveyors are frequently utilised in today's contemporary ports as continuous transportation equipment, particularly in the delivery of coal and mineral powder. Pneumatic conveying systems may be built and operated with care and thought to provide outstanding performance with minimal product deterioration. How these systems function is based on a lot of science. A properly designed air flow system to transport bulk material from one point to another is often the most practical means. Pneumatic conveying systems usually require less plant space, it's simple to automate, and it's simple to set up. There are certain restrictions to pneumatic conveying systems, such as material size and temperature. However, they still provide many benefits. They are beneficial in managing or decreasing product loss, increasing dust management, and so improving overall plant conditions, in addition to being highly cost effective.

### III. Conclusion

After calculating all the values by analytically method and analysing the main components of belt conveyor system. It is concluded that the belt conveyor system works safely. The system suggested is easy to install. The system now has a higher level of security and dependability. There are no sophisticated components required for the system to work.

### Reference

- [1] Shirong Zhang, Xiaohua Xia "Modelling and energy efficiency optimization of belt conveyors", Department of Automation, Wuhan University, Wuhan 430072, China Department of Electrical, Electronic and Computer Engineering, University of Pretoria, Pretoria 0002, South Africa 'www.elsevier.com/locate/apenergy' 16 March 2011.
- [2] M.A. Alspaugh "Latest Developments in Belt Conveyor Technology", Overlandveyor Co., Inc. Presented at MINExpo 2004 Las Vegas, NV, USA September 27, 2004
- [3] . Marcus Haines "Development of a Conveyor Belt Idler Roller for Light Weight and Low Noise"
- [4] Mustafa ND, Faudzi AAM, Abidin AFZ, Osman K, Suzumori K (2013) Generalized predictive controller using bat algorithm for double acting pneumatic cylinder. In: 2013 IEEE student conference on research and development, pp 572–576, <https://doi.org/10.1109/SCORED.2013.7002657>
- [5] M. Jimenez · E. Kurmyshev · C.E. Castaneda in Experimental Techniques in entitled, "Experimental Study of Double-Acting Pneumatic Cylinder" (2020)
- [6] Olanrewaju T. O., Jeremiah I. M., Onyeonula P. E. in AgricEngInt: CIGR Journal in entitled, "Design and fabrication of a screw conveyor" (2017)
- [7] Larry Goldbeck (9th International Conference-2007) "Improving Belt Conveyor Safety with Better Procedures and Training"

- 
- [8] Anath, K. N. and Rakesh, V. (2013). Design and Selecting Proper Conveyor Belt. *Int. Journal of Advanced Technology*. Vol. 4(2) pp. 43-49.
- [9] Tetsuya Akagi, Shujiro Dohta, Feifei Zhao, and Takahiro Fujikawa, "Development and Attitude Control of Flexible Robot Arm Using Flexible Pneumatic Cylinder with Simple Structure", 2001.
- [10] P. Kali Sindhur, "Cutting mechanism by giving feed through Geneva mechanism (P.Kali Sindhur, April 2015)e, *Engineering & Technology*, vol 2 issue 4, April 2015.
- [11] Han Jiguang Yu Kang, "Analysis & Synthesis of Geneva mechanism with elliptic crank", *International journal of hybrid information technology*, vol 8 No.8, 2015. Page no: 253 – 260
- [12] Kewu Zhu, Jun Yao, Chi-Hwa Wang on The Electrostatics of Pneumatic Conveying of Granular Materials,
- [13] N. Sambathkumar, K. Sivakumar, D. Ganesan, M. Krishnakumar. Design and Fabrication of Material Inspection Conveyer, *International journal of research in Aeronautical and Mechanical Engineering* 2(3), March 2014. ISSN 2321-3051.
- [14] Garg Uttam, Bhowad Rugved, Rahul Chorgha and Yadav Sachin, Vertical Material Handling System. *International Journal of Mechanical Engineering and Technology*, 6(2), 2015, pp. 19 - 29.
- [15] Felix Creutzig "On Economic and Environmental evaluation of Compressed Air Cars". *Et al2009 Environ.Res. Lett.* 4044011.
- [16] Mr. KunjanShinde "Compress Air," *IJRMET* ISSN: 2249-5770 Vol.7, Issue 04, Nov-2016.
- [17] P. S. Garudkar" Design of Material Handling System for Kit Packing Machine", *International Journal of Applied Engineering Research* ISSN: 0973-4562 Volume 13, Number 5 (2018) pp. 75-78