

Analysis and Control Of Grid Connected Multi Terminal HVDC System

G.Balaji¹, K.S.Srikanth²

¹(EEE Department, AIMS College of Engineering, Mummdivaram)

²(EEE Department, AIMS College of Engineering, Mummdivaram)

Abstract : When connecting a wind park (WP) to the main grid (MG) by way of an HVDC Light transmission system, the WP becomes decoupled from the MG, which results in several technical and economical benefits, on a variety of aspects, for transmission system operators (TSOs), WP developers and WTG manufacturers. Perhaps most important for TSOs is that an HVDC-Light connected WP becomes comparable to a normal power plant; the MG-side HVDC Light converter can be directly connected to a control or power dispatch center. A desirable consequence is also that AC faults appearing in the WP or MG grid will not be propagated by the HVDC Light transmission system, which has several desirable consequences such as possibly reduced mechanical stresses on the WTGs. This paper presents operation and control strategies of multi-terminal HVDC transmission system (MTDC) using voltage source converters (VSCs) for integrating large offshore wind farms. The framework and operation principles of the proposed system are described and control strategies for coordinating various VSCs are proposed. DC voltage control based on the DC voltage-current (V-I) droop characteristic of grid side converters is implemented, to ensure stable system operation and flexible power dispatch between various onshore AC grids. To validate the performance of the proposed control strategies, a typical four terminal MTDC networks, which connecting two offshore wind farms with two onshore AC grids, is established in PSCAD/EMTEC. Simulation results under normal and abnormal operation conditions verify the satisfactory performance of the proposed control strategy and accuracy of the theoretical analysis.

Keywords: Control, HVDC, multi-terminal, voltage source converter, wind farm.

I. Introduction

As wind power is a kind of environmental friendly energy and abundantly available in nature, the China government has set a target of developing 200GW wind farms by 2020 in order to deal with global warming and achieve a goal that 15% of power consumption is provided by renewable energy. Offshore wind farms will increase to 30GW according to the target and are developing rapidly in recent years. Integrating the offshore wind farms to the grid over a long distance is one of the main challenges facing researchers. Previous studies have indicated that high voltage DC (HVDC) transmission has a lot of advantages over traditional AC transmission, including fewer cables required, not affected by the cable charging current and flexibly controlled power flow [1], [2]. Compared with line commutated converter (LCC) HVDC, the VSC-HVDC shows many advantages [3]-[7]. These include avoiding commutation failure, the independent control of active and reactive power, no voltage polarity reversal required to reverse power, producing less harmonic, less filters required and continuous AC bus voltage regulation. Because of the above reasons, VSC-HVDC is considered as a promising solution to integrating large offshore wind farms into onshore AC grids and has attracted a lot of research [5]-[8]. In VSC-HVDC, VSC multi-terminal HVDC (VSC-MTDC) transmission system, which consists of more than two converters connected through DC cables, can reduce the number of converters and improve the flexibility and reliability, when compared to numerous point to point HVDC systems. But the challenge is that the operation and control of VSC-MTDC is more complex. Various control strategies have been proposed for VSC-MTDC [9]-[11]. In [9], a voltage margin control method was proposed, in which each converter station in the system was given a marginally offset DC voltage reference. At any time, only one converter is used to control the DC voltage in this method. Reference [10] designed a control method based on the voltage-power characteristic of the converters for a MTDC system without fast communication. In [11], a current matching control was used to control the DC current and power sharing ratio among the AC grids. This kind of control depended on the communication equipment to transmit current information. The deficiency of the above control methods is that they can't allow multiple converters to control the DC voltage and change the power sharing ratio between the receiving AC grids without communications simultaneously. This paper proposes a control method, which allows multiple converters to control the DC voltage and can dispatch the

power between the receiving AC grids of MTDC system at a pre-defined ratio without the use of communications between terminals.

Transmission System Operators (TSOs) stipulate a fault ride-through (FRT) capability of wind farms down to zero voltage for fault durations up to 150 ms [3], [4]. However, IGBT valves have no reverse blocking capability and the power flow from the OWFs cannot be interrupted by the offshore VSCs. As the onshore VSCs are not able to deliver the total OWF power to the onshore ac grid during faults, the resulting power imbalance charges the capacitances in the dc network. Without any countermeasures, the dc network voltage may increase up to intolerable levels and cause operation of the dc overvoltage protection of the HVDC system. This can be avoided by using a dc chopper (or choppers) to dissipate all the waste energy in breaking resistors. However, this solution leads to higher investment costs. Therefore, FRT methods based on fast reduction of power generation in OWFs have been discussed in recent literature [5]-[9]. These methods limit the dc network voltage increase and help reducing the size of the dc chopper or eliminate its requirement completely. This paper illustrates the implementation of various FRT methods to a system of OWFs composed of doubly fed induction generator (DFIG) type wind turbines (WTs) and connected to an ac grid through a modular multilevel converter (MMC) topology based MT-HVDC. Various realistic onshore ac fault scenarios are simulated using EMTPRV to compare the performances of the implemented FRT methods. The simulation results demonstrate that the implemented FRT methods limit the increase in dc voltage at tolerable values and eliminate the dc chopper requirement completely. The first part of this paper presents the MMC-HVDC and DFIG systems briefly. The second part gives an overview on FRT methods and their implementation to an MT-HVDC connected OWF system. The simulated system and simulation results are presented in the last part.

II. Modular Multilevel Converter (Mmc)Hvdc

Recent trends on VSC-HVDC technology include MMCs. The MMC uses a stack of identical modules, each providing one step in the resulting multilevel ac waveform [10], [11]. Filter requirements are eliminated by using large number of levels per phase. Scalability to higher voltages is easily achieved and reliability is improved by increasing the number of SMs [12]. The MMC topology considered in this paper is based on the preliminary design of a 401-level MMC-HVDC system planned to interconnect the 400 kV networks of France and Spain by 2013 [13]. The onshore MMCs use a vector control strategy that calculates a voltage time area across the equivalent transformer/arm reactor which is required to change the current from present value to the reference value. The reference dq0-frame currents from the outer controller are calculated based on either preset AC and DC voltages, or preset active and reactive power. The inner controller permits controlling the converter AC voltage that will be used to generate the modulated switching pattern. The active and reactive currents in the dq0-frame can then be independently controlled via a proportional-integral (PI) control [14]. The reactive power control includes an AC voltage override block intended to maintain the voltage within acceptable limits. The function of the offshore MMCs is to transmit the active power generated by the OWFs and to set a voltage reference for the DFIG type WT generators. As shown in Fig. 1, this is achieved using a simple voltage magnitude controller consisting of a PI regulator and feedback from measurement (v_{ac}). A fixed nominal frequency (\hat{f}) is supplied to the offshore MMC output voltage (\hat{v}). In other words, the offshore MMC is controlled as a voltage source with constant ω . As the controller does not contain a current control, current limitation can be achieved by blocking IGBTs during a severe fault on the offshore ac network.

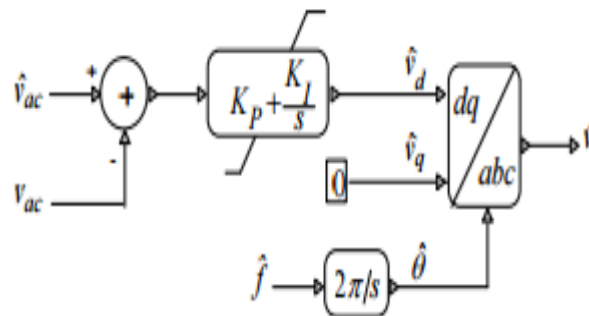

III. DFIG Based Wind Turbines

The basic configuration of a DFIG WT is shown in Fig. 2. The stator of the wound rotor induction machine is connected directly to the power grid and the rotor is connected to the power grid through an ac-ac converter system. The ac-ac converter system consists of two three-phase pulse-width modulated (PWM) converters (grid-side and rotor-side converters) connected by a dc bus. A line inductor and an ac filter are used at the grid-side converter (GSC) to improve power quality. A crowbar is used to protect the rotor-side converter (RSC) against over-currents and the dc capacitors against over-voltages. During crowbar ignition, the RSC is blocked and the machine consumes reactive power. Therefore, the dc chopper is widely used to avoid crowbar ignition. The control of the WT is achieved by controlling the RSC and GSC utilizing vector control techniques. Vector control allows decoupled control of both real and reactive power. The RSC controls the active and reactive powers delivered to the grid, and follows a tracking characteristic to adjust the generator speed for optimal power generation depending on wind speed. On the other hand, the GSC is used to maintain the dc bus voltage and to support the grid with reactive power during faults.

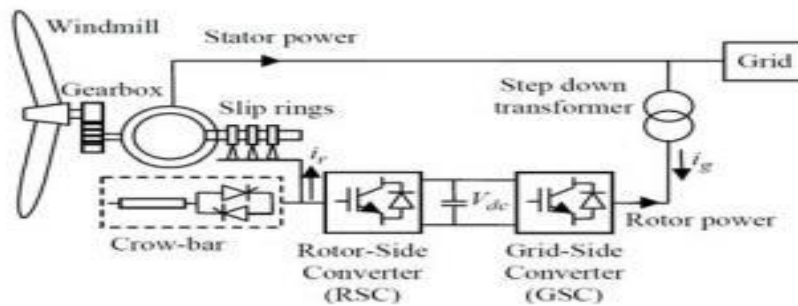
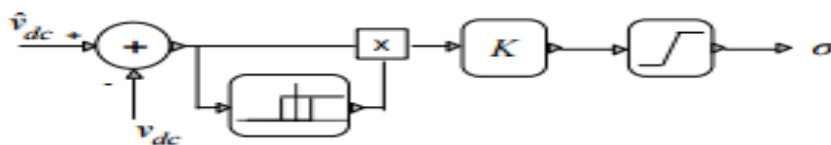

Figure. 2. Schematic diagram of a DFIG wind turbine

IV. Fault Ride Through Methods

A. Active Current Reduction Through Offshore MMC In this method, the offshore MMCs switch to decoupled power control mode following onshore ac fault detection and reduce the injected active power to the dc network. However, as the WTs are also operating in power control mode, the interaction between offshore MMCs and WT controls may lead to excessive overvoltages in the OWFs ac grid and mechanical stress on the WTs. Additional control algorithms can be implemented in WT controls to respond with power reduction to these overvoltages [5]. However, this method is less suitable in practice due to the slow rate of power reduction [8].

B. Active Current Reduction of WTs Through Power Reference Adjustment In this method, the power reduction factor of the WTs is determined by a central dc voltage controller located at the offshore MMC (see Fig. 3). The dc voltage controller is activated when the dc network voltage exceeds a pre-specified limit and is deactivated again when it falls below the other pre-specified limit. It is a simple proportional control in which the power reduction factor (the increase in dc network voltage in order to adjust the WT power output set value P)



V. Proposed Approaches For FRT Provision In MTC Grids

A. Introduction The converter current limits are responsible for reducing the onshore HVDC–VSC active power injection capability during voltage sags. Offshore WF commonly operate in a maximum power extraction philosophy and offshore HVDC–VSC injects the incoming power into the dc grid. Therefore, during an ac mainland fault, a significant power reduction occurs in the HVDC– VSC terminal connected to the faulted area. Without the use of any specific strategy (which are addressed hereafter), the offshore WF will remain operating under a maximum power extraction strategy. Consequently, the dc power imbalance will result on dc over voltages in the different MTDC grid nodes depending on the pre-disturbance active power flows and on the MTDC grid topology [6]. Nonetheless, dc over voltages must be controlled in order to avoid equipment damages and provide the expected flexibility in terms of FRT capability.

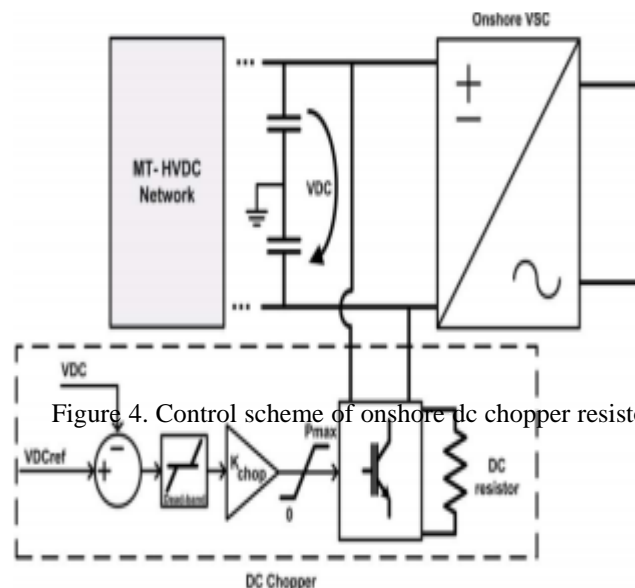

Figure 4. Control scheme of onshore dc chopper resistor.

In order to mitigate the dc voltage rise effect, three control strategies are proposed and tested. The first one consists on a conventional solution based on dc chopper resistors installed at onshore VSC-level and is considered as a reference case. The other two strategies rely on innovative communication free solutions that exploit the control flexibility of both offshore HVDC–VSC converter stations and wind generators to perform fast active power reduction at the wind generator level. These control strategies are based on the implementation of local control rules at offshore converter stations and at wind turbine generators and are intended to avoid the use of solutions based on dc chopper resistors. B. Onshore DC Chopper A dc chopper consists on a dc resistor controlled through a power electronic switch and it is installed at the HVDC–VSC onshore converter station as it is depicted in Fig6. A detailed sizing of a dc chopper-based solution for FRT compliance in MTDC grids is out of the scope of this paper (as previously mentioned, this type of solution is considered only as a reference case). Nevertheless, it depends on several factors, namely the MTDC grid power in-feeds (power in-feeds from offshore WF or from other mainland ac grid areas) as well as on the mainland grid connection points and its electrical distance. In this case, a simple approach based on a worst case scenario was considered. The worst case condition corresponds to a situation where all HVDC–VSC stations are operating at the nominal power. In case of a fault, healthy converters (connected to non-faulted ac mainland grids) are not able to increase their power injection and power dissipation in chopper resistors is required in order to mitigate the dc voltage rise. Based on this assumption, each dc chopper must be sized to dissipate the nominal power of the HVDC– VSC to which it is connected.

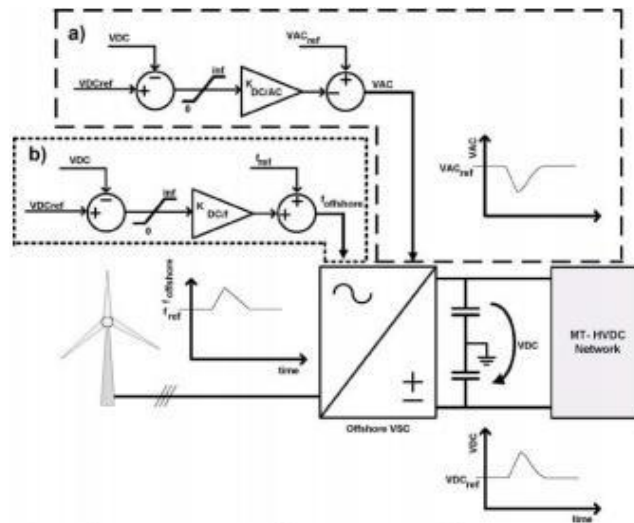

Figure 5. Control scheme for FRT provision based on dc voltage: (a) AC offshore grid voltage control. (b) AC offshore grid frequency control.

The activation of each dc chopper control strategy is based on a dc voltage threshold that will trigger power dissipation in the resistor. In terms of RMS system modeling, the dc chopper active power dissipation is locally regulated based on a proportional control rule having as input the positive dc voltage deviation (over voltage magnitude) [5]. The dc chopper de-activation occurs if: (1) the dc voltage reaches a value below the threshold activation level (eg.: after fault clearance) or; (2) the chopper resistor temperature overreaches the maximum value (thermal protection tripping), meaning that the resistor maximum energy dissipation capability has been overreached. This specific situation is often related to a permanent fault event and must be handled by additional control schemes to perform permanent active power reduction at offshore WF-level.

B. FRT Provision through Wind Turbine Power Regulation

Modern wind turbines connected to ac grids in onshore applications are FRT compliant, coping with the requirements of many grid codes [2]. However, MTDC grids decouple the offshore WF and the onshore ac grid. Therefore, in order to derive a communication-free solution to provide FRT in MTDC grids, strategies exploiting the dc over voltages resulting from onshore ac faults can be advantageous. The main objective is the implementation of local controllers at the offshore VSC and at the wind generators enabling them to perform fast active power regulation as it is generally depicted in Fig. 4. The envisioned control strategies exploit MTDC grid voltage rise in order to control (1) the offshore ac grid voltage or (2) the offshore ac grid frequency.

C. Local Controls at the Wind Generator Level

As previously mentioned, PMSG and DFIG were assumed to be used in offshore WF in order to demonstrate the feasibility and evaluate the performance of the proposed wind generators' active power control strategies. Regarding PMSG, the wind generator local control for fast active power regulation is set to dissipate active power proportionally to ac offshore grid voltage (case 1) or frequency variations (case 2). To achieve a fast response, it is assumed the power dissipation is made at the wind generator chopper resistor installed on the dc bus bar of the ac-dc-ac full converter [2], [6], while having the advantage of keeping the generator side decoupled from the transient phenomena. For the DFIG, the active power regulation is naturally achieved for the ac voltage regulation strategy, since the controlled voltage sag in the offshore ac grid leads to the generator de-magnetization, increasing slightly its angular speed and consequently reducing the injected power. In this

case, inrush currents resulting from the demagnetization of DFIG are a critical issue due to the current limits of the HVDC-VSC station connected to the offshore ac grid. In order to overcome this drawback, the control strategy presented in [3] is adopted, as it was previously mentioned. Compared to conventional DFIG control strategies, it presents the advantage of assuring a considerable limitation of the stator currents following the voltage dip, while limiting also the rotor current and avoiding the need of the crowbar. The control principle exploits the possibility of allowing the DFIG rotor speed increase in coordination with the control of the wind turbine pitch angle in order to limit the acceleration phase and to avoid stability issues. Regarding the frequency-based active power regulation strategy in the DFIG, a supplementary control is used in the speed control loop implemented in the rotor side converter which allows a rotor speed increase to achieve a fast reduction of active power generation.

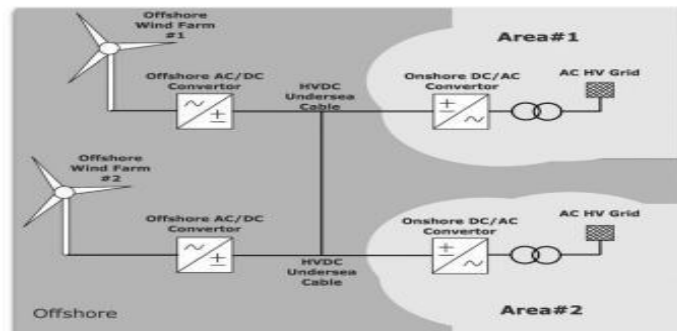

Figure.6. MTDC grid test system.

VI. Simulation Result

In order to characterize the transient overvoltage phenomena in MTDC grids, a 500 ms three-phase fault was simulated near Area #1 onshore converter ac terminals at 1 s

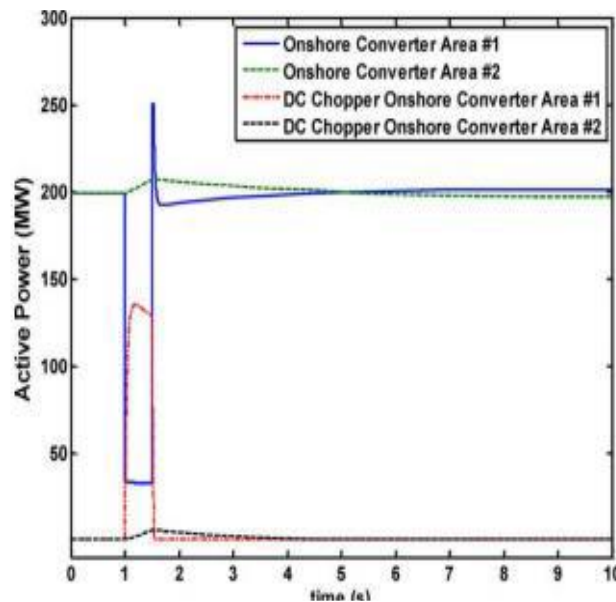

Figure 9. Onshore converter and dc choppers active power Onshore Chopper Resistors

In order to define a reference case, the first analysis consisted on evaluating the behavior of MTDC grid, namely regarding dc voltage profile and active power flows, when the FRT capability is to be assured

through the use of two dc choppers installed on each dc onshore terminal. The obtained results are depicted in Figs.8 and 9, where it is possible to observe that a small dc overvoltage took place during fault occurrence. It is important to note that for this specific set of simulations, offshore WF have not change their power injection since, as aforementioned, the dc grid decouples the interconnected ac areas and the dc power balance is achieved through external solutions in relation to the WF.

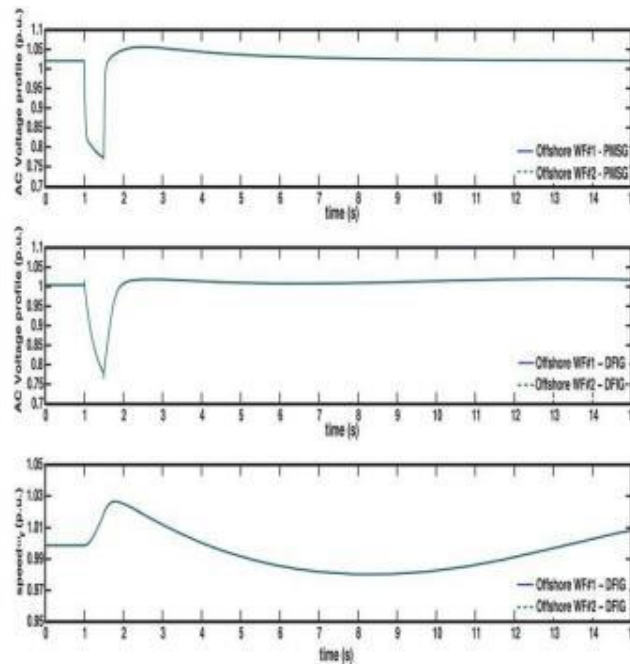

Figure10. AC voltage profile at offshore network and DFIG speed.

VII. Conclusion

This specific report gives a dialogue for the id along with growth connected with communication-free command strategies for FRT provision on MTDC grids interconnecting offshore WF together with hvac mainland grids. The suggested command strategies for endowing MTDC grids together with FRT potential write about a typical quality: this accommodation/dissipation connected with productive energy by offshore WF in order to abate this dc voltage surge consequence. The established option good using onshore chopper resistors is an efficient option which might be very easily put in place due to the fact the command will depend on nearby measurements. Despite the fact that using these kinds of method fully decouples offshore WF in the principal along with hvac mistake, that's benefic in connection with lowered strain problems for that wind turbines, the dimensions of the desired dc chopper resistors my personal impede the request by a cost-effective point of view. Alternative methods for that mitigation connected with MTDC in excess of voltages use productive energy lowering on the generator amount through the exploitation of a communication-free command method which in turn will depend on some nearby controllers for being installed on the offshore converter train station along with on the turbine amount. The suggested approaches work well relating to productive energy legislation in order to guarantee FRT submission by MTDC grids. The attained final results make it possible for deciding in which suggested command approaches are generally strong underneath extremely nerve-racking problems, are generally independent of the dc grid topology along with with the pre-disturbance dc grid energy dispatch. This is a key qualification on the interoperability connected with solutions by various suppliers. The significant benefit of these types of approaches relies on a smaller amount expenditure in connection with implementation with the necessary command functionalities. Even so, these types of approaches lead to a few strain in excess of DFIG regarding velocity different versions (similarly from what happens within wind turbines linked with onshore grids). In addition, modest in excess of currents are generally observed in this linked HVDC-VSC along with should be considered within the style period.

References

- [1] European Union Project TWENTIES. [Online]. Available: <http://www.twenties-project.eu> Oct. 2012
- [2] K. Bell, D. Cirio, A. M. Denis, L. He, C. C. Liu, G. Migliavacca, C. Moreira, and P. Panciatici, —Economic and technical criteria for designing future off-shore HVDC grids,| in Proc. Power Energy Soc. Innovative Smart Grid Technol. Conf. Eur., 2010, pp. 1–8.
- [3] Intelligent Energy Europe. OffshoreGrid Project, 2012. [Online]. Available: <http://www.offshoregrid.eu/>
- [4] Intelligent Energy Europe. Tradewind Project, 2012. [Online]. Available: <http://www.trade-wind.eu>
- [5] T. Ackermann, —Transmission systems for offshore wind farms,| IEEE Power Eng. Rev., vol. 22, no. 12, pp. 23– 27, Dec. 2002.
- [6] N. B. Negra, J. Todorovic, and T. Ackermann, —Loss evaluation of HVAC and HVDC transmission solutions for large offshore wind farms,| Elect. Power Syst. Res., vol. 76, no. 11, pp. 916–927, 2006.
- [7] N. Flourentzou, V. G. Agelidis, and G. D. Demetriades, —VSC-based HVDC power transmission systems: An overview,| IEEE Trans. Power Electron., vol. 24, no. 3, pp. 592–602, Mar. 2009.
- [8] O. Gomis-Bellmunt, J. Liang, J. Ekanayake, R. King, and N. Jenkins, —Topologies of multiterminal HVDC-VSC transmission for large offshore wind farms,| Elect. Power Syst. Res., vol. 81, no. 2, pp. 271–281, 2011.
- [9] O. Gomis-Bellmunt, J. Liang, J. Ekanayake, and N. Jenkins, —Voltage—current characteristics of multiterminal HVDC-VSC for offshore wind farms,| Elect. Power Syst. Res., vol. 81, no. 2, pp. 440–450, 2011.
- [10] S. Cole, J. Beerten, and R. Belmans, —Generalized dynamic VSC MTDC model for power system stability studies,| IEEE Trans. Power Syst., vol. 25, no. 3, pp. 1655–1662, Aug. 2010.